



# Module 11: Transit and the Connected Vehicle Environment/Emerging Technologies, Applications, and Future Platforms

## Table of Contents

Module Description .....	2
Introduction/Purpose.....	2
Samples/Examples .....	4
Reference to Other Standards .....	5
Case Study.....	7
Glossary .....	8
Acronyms .....	12
References .....	13
Study Questions .....	14
Icon Guide.....	15



## 1. Module Description

This module will provide participants with an introduction to the transit Connected Vehicle environment to understand its potential benefits to transit operators and users and how to start preparing for the transit applications within the connected vehicle environment. This module will outline some of the data that may be exchanged between connected devices and the CV and Intelligent Transportation Systems (ITS) standards that support those exchanges and illustrate how that information may be used to create a safe, stable, interoperable, and reliable transit system.

It is essential that transit agencies use standards in deploying connected vehicle technologies to maximize the benefits from the connected transit vehicle environment. Participants will learn what connected vehicle standards exist, where to find the standards, and how to use the connected vehicle standards to procure, implement, and operate standards-based devices and equipment.

## 2. Introduction/Purpose

The connected vehicle environment has the potential to transform surface transportation systems such that vehicular crashes will be significantly reduced, operators of the surface transportation systems will have access to more accurate system performance data, travelers will have access to specific traveler information, and will allow the surface transportation systems to be optimized to minimize environmental impacts.

The Connected Vehicle environment currently being researched and pilot deployment testing by United States Department of Transportation (USDOT) has the potential to transform surface transportation systems via wireless connectivity. As a result, vehicular crashes are significantly reduced, travelers have access to specific traveler information, and operators of the surface transportation systems have access to more accurate system performance data, thereby optimizing surface transportation systems to minimize environmental impacts. For transit operators, this environment provides an opportunity to implement emerging safety and mobility applications to improve public transit service by increasing highway safety, transit productivity, mobility-efficiency, and accessibility while providing its users with better transit services and travel information.

Deploying these connected vehicle standards will support interoperability, minimize future integration costs, make procurements easier, and facilitate regional and national interoperability. The focus of this module is transit applications. This document covers pertinent details and references for standards for further reading.

### **Communications Technologies Alternatives for CV Environment**

At present, focus is on two types of suitable CV communication technologies: DSRC used in US and emerging C-V2X, cellular platform. The following information is provided for outlining aspects of both technologies.

### **General Information on DSRC**

The ITS Program definition of connected vehicles includes both 5.9 Gigahertz (GHz) Dedicated Short Range Communications (DSRC) and non-DSRC technologies as means of facilitating communication



for vehicle-to-vehicle (V2V) and vehicle-to-infrastructure (V2I) applications. Non-DSRC technologies (e.g., Radio Frequency Identification, Worldwide Interoperability for Microwave Access, Wi-Fi, Bluetooth, and cellular communication) enable use of existing commercial infrastructure for additional capacity support but may not meet the low-latency needs of transmitting safety-critical information. DSRC is a two-way wireless communications protocol suite that integrates the IEEE 802.11, 1609.x standards, SAE J2735, and SAE J2945. The USDOT is pursuing DSRC because of its low-latency and high-reliability performance that can be used to reduce fatalities through active safety applications, including collision avoidance, incident reporting and management, emergency response, and pedestrian safety. Furthermore, DSRC supports the close-range communication requirements to distribute Signal Phase and Timing information for intersection-based applications and localized roadway warnings. This subject is covered under a TSP-transit signal priority.

### **General Information on Cellular Technology (5G- Long Term Evolution-LTE)**

Cellular C technology is working to advance to 5G connectivity for higher bandwidth, accessibility and network density. 5G is a radio access technology that will be implemented by retrofitting existing platforms such as 2G, 3G, 4G, and Wi-Fi. Literature indicates that 5G is still evolving as the single cellular platform to support the different needs of today's users; it will need to coexist with existing platforms until fully implemented. By the installation of many small cell towers, a shorter range is obtained which allows for a higher bandwidth and faster speeds. Due to the installation requirements, 5G services will be rolled out to densely populated areas initially and will take time to expand to rural or less dense areas. This progressing situation is also known as LTE-long term evolution. Related terminology also includes NR-New Radio, which is part of 3GPP details.

It would be possible to leverage the standards developed by a 5G cellular network to develop 5G-based V2X technologies. With a 5G-based V2X system, operations would be very similar to a DSRC-based system, in that dedicated equipment would be required to generate and receive data between vehicles and the infrastructure. 5G V2X systems would use the same 5.9 GHz band for communications between vehicles and infrastructure as DSRC systems; the differences lie in the equipment and backhaul communication configurations. While 5G V2X systems have not yet been developed or piloted, it is expected that most of the DSRC-based applications would also be used in a 5G V2X environment.

**5G Pros:** The development of larger-scale 5G cellular communications networks is expected to enable a future 5G-based V2X network. As a result, it is possible that much of the infrastructure costs in a 5G V2X network will be borne by telecommunications companies (although this results in some cons, listed below). 5G V2X technology is also expected to be able to use much of the same infrastructure as a DSRC-based system, ensuring that much of the investment in DSRC systems are not "lost" to new technology. Many DSRC equipment manufacturers are currently developing both RSU and OBU hardware to have both DSRC and 5G V2X (PC5 Interface) capabilities, allowing for the leveraging the benefits of both technologies.

**5G Cons:** The greatest con of 5G V2X communication is that 5G wireless technology simply does not exist yet. There are some pilot deployments of 5G communications networks that telecommunications companies have deployed in the United States, but full-scale deployment has yet to begin. 5G V2X deployment can only occur where a 5G cellular network exists. As a result, widespread deployment of 5G V2X solutions will be limited geographically to where reliable 5G communications capabilities are available. 5G cellular network rollout is expected to take several years and possibly longer in rural areas. A transitional period will likely occur over the course of



many years, emulating the transition from 3G to 4G LTE. Release 16 on 5G NR from 3GPP is expected in an early 2020 timeframe.

Specific 5G V2X standards and equipment have not yet been developed. It is expected that 5G V2X technology will have to undergo the same robust compatibility testing and development for use in an automotive environment as DSRC has done. Efforts are underway in the industry to address it.

### **Over the Air (DSRC) vs Point-to-Point (C-V2X) Communication**

The nature of a 5G V2X revolves around “point-to-point” communications, meaning that devices would communicate directly with each other (and the associated 5G cellular network). As a result, exchanged data would not be available “open air,” such as would be the case with a DSRC network. As a result, data generated by equipped vehicles would not be readily available to transportation infrastructure owners and operators. This eliminates a significant attraction of a connected vehicle network: using data to assist with the real-time and near-real time ability of managing a transportation network. Therefore, while a 5G V2X system may reduce public sector infrastructure costs, agencies will have no access to data unless they sign a contract with the private service provider. This allows private companies to have control over the data collected, as it will not be available for everyone’s use. (Ref.19)

In short, C-V2X employs the following two complementary transmission modes: first, direct communications between vehicles, between vehicles and infrastructure, and vehicles and other road users, such as cyclists and pedestrians. In this mode, C-V2X works independently of the cellular networks. Second, network communications, in which C-V2X employs the conventional mobile network to enable a vehicle to receive information about road conditions and traffic in the area.

## **3. Example: Enhanced Transit Safety Retrofit Package (E-TRP)**

The enhanced TRP (E-TRP) is based on experience gained and lessons learned from the earlier system, with the current focus on reducing pedestrian and vehicle conflicts with transit buses in the greater Cleveland, Ohio metro area. The E-TRP features enhanced versions of the Pedestrian in Crossing Warning and Vehicle Turning Right in Front of Bus Warning CV applications. Key technologies deployed include DSRC for vehicle-to-vehicle and vehicle-to-infrastructure communication, High-precision Global Navigation Satellite System for vehicle tracking, and Forward Looking Infrared cameras for enhanced pedestrian detection.

The following brief summary of E-TRP project performance measures and key findings from Cleveland PCW application is presented below to illustrate certain aspects of CV transit safety as outlined in the key findings. Such objectives are found in several CV deployment projects pertinent to transit safety applications. (“Connected Vehicle (CV) Infrastructure – Urban Bus Operational Safety Platform Project Report”, Ref.21).



Evaluation Criteria	Performance Measures	Key Findings
System Performance	• False Alarm Rate	• 81% correct alerts (10% incorrect alerts and 9% false alarms).
Safety Impact	• Collision Reduction	<ul style="list-style-type: none"> <li>• 16% increase in drivers' response (braking) to PCW warning situation.</li> <li>• 18% decrease in average drivers' reaction time (braking) to PCW warning situation.</li> </ul>

Integrated Dynamic Transit Operations related to Dynamic Mobility Applications program are also actively researched and being deployed for CV mobility benefits. IDTO will provide transit users and riders the means to ensure successful transit transfers, to make real-time trip requests through personal mobile devices, and to identify and accept potential ridesharing opportunities along a given travel route. For further information, please consult USDOT report-FHWA-JPO-12-083 at <https://rosap.ntl.bts.gov/view/dot/3451>

#### 4. Reference to Other Standards

The following list summarizes pertinent standards referred in this module and deployed in transit CV applications. Note, several standards have been revised in recent years and users must deploy latest published versions.

- ASTM E2213-03: Standard Specification for Telecommunications and Information between Roadside and Vehicle Systems (DSRC/MAC/PHY). (This standard is now part of IEEE 802.11 (2016))
- IEEE 1609.x Wireless Access for Vehicle Environments (WAVE) Family
- IEEE 802.11p (WAVE DSRC), now replaced with IEEE 802.11 (2016)
- SAE J2735 Data Dictionary standard
- SAE J2945.x Interface standards

##### Completion of key standards

- SAE J2945/1 V2V Safety Application
- SAE J2945/2 V2V Awareness Application
- SAE J2945/9 Vulnerable Road User Application
- Conformance test specifications for SAE J2945/1

##### Revisions of other standards

- SAE J2735 DSRC Message Set Dictionary
- IEEE 1609.2 Security Services for Applications and Management Messages
- IEEE 1609.2.1 Security Credential Management System (SCMS) is pending
- IEEE 1609.3 Networking Services
- IEEE 1609.4 Multi-channel Operation

##### SAE J2735 Basic Safety Messages (BSM) Standard

The BSM is broadcast from vehicles over the 5.9 GHz DSRC band. Transmission range is approximately 1,000 meters. The BSM consists of the following two parts:

##### BSM Part 1:

- Contains core data elements, including vehicle position, heading, speed, acceleration, steering wheel angle and vehicle size



- Is transmitted at an adjustable rate of about 10 times per second, based on radio channel loading

**BSM Part 2:**

- Contains a variable set of data elements drawn from an extensive list of optional elements. Some of these elements are periodically included in a subset of BSM messages at a frequency that is time dependent while others are included if certain triggering events occur, e.g., ABS activated.
- The data elements are added to Part 1 and sent as part of the BSM message, but are transmitted less frequently in order to conserve bandwidth

The BSM message includes only current snapshots (with the exception of path data, which is itself limited to a few seconds worth of history data or future path prediction). It is important to note that the fact that a data element is defined as an element of Part 2 of the BSM in the Society of Automotive Engineers (SAE) J2735 standard does not necessarily mean that it will be provided by vehicle menu.

**DSRC Standards Stack and Operation Details**

IEEE 802.11p (now 802.11) is a single channel operation-that is data packets are placed on whichever channel is selected- however, since US DSRC offers seven channels, upper layer IEEE 1609.4 provided multi-channel operations with service channels (SCHs) switching channels mechanism to enable a single radio device to access multi-channels spectrum, bringing WAVE to CV environment.

This is the reason why we call DSRC WAVE architecture or sometimes WAVE devices (OBU or ASD, and RSE.)

**What is channel switching?**

The MAC sub-layer has an extension that supports channel switching, defined in IEEE 1609.4. One of the seven 10 MHz channels (178) is dedicated as the control channel (CCH) while others work as SCHs. Channel switching allows concurrent access of CCH and SCHs. This is achieved by dividing each 100 ms into a 46 ms CCH interval and a 46 ms SCH interval, each followed by a 4 ms guard interval.]

IEEE 1609 family standards also tells us how the application that utilize the WAVE will function in the high-speed WAVE environment based management activity defined in IEEE1609.1, security protocol defined in IEEE 1609.2 and the network protocol defined in IEEE 1609.3 and they provide the physical channel access defined in IEEE 802.11 (802.11 p) to give support to IEEE 1609.4 protocol. The development of this standards for WAVE application is done such that WAVE device able to accommodate an architecture that support two channels i.e. CCH and SCH. These channels provide the multiple channel operation in WAVE and has advantage related to security. The role of CCH is to transmit the WAVE short message and announce the WAVE services whereas the SCH is responsible for application interaction and transmission. SCH 172 only broadcasts BSMs for safety applications.

**Overall DSRC Operation with DSRC Stack**

The DSRC or WAVE stack and used in CV wireless connectivity within the multi-channel operations of DSRC.

**Why WSM Concept:** In the vehicular environment, many data packets are sent directly over the air from the source to the destination, so routing is less of an issue. In order to avoid the packet overhead associated with internet protocols, a minimum of 52 bytes for a UDP/IPv6 packet, the IEEE



1609 WG defined a new Layer 3 protocol that is efficient for these 1-hop transmissions: the WAVE Short Message Protocol (WSMP). Packets sent using WSMP are referred to as WAVE Short Messages (WSMs). WSM is a message structure and its movements are controlled by WSMP, as defined below.

**WSMP defined in IEEE 1609.3**, is the networking service in DSRC and serves the purposes of the network layer and transport layer from the TCP/IP stack. WSMP defines a message type that is efficient for 1-hop transmission. The message type is called Wave Short Message (WSM), whose minimum header size is 5 bytes. Compared to UDP over IPv6, which is a similar configuration in the TCP/IP protocol stack that requires a minimum of 52 bytes of header, WSM's overhead is much smaller and causes less congestion. Since channel congestion is a significant concern in DSRC, the efficiency of WSMP is quite valuable. On the other hand, being such a minimum protocol (small number of bytes packet), WSMP does not provide many powerful transport layer functionalities other than multiplexing, which is achieved through the provider (Provider Service Identifier-PSID).

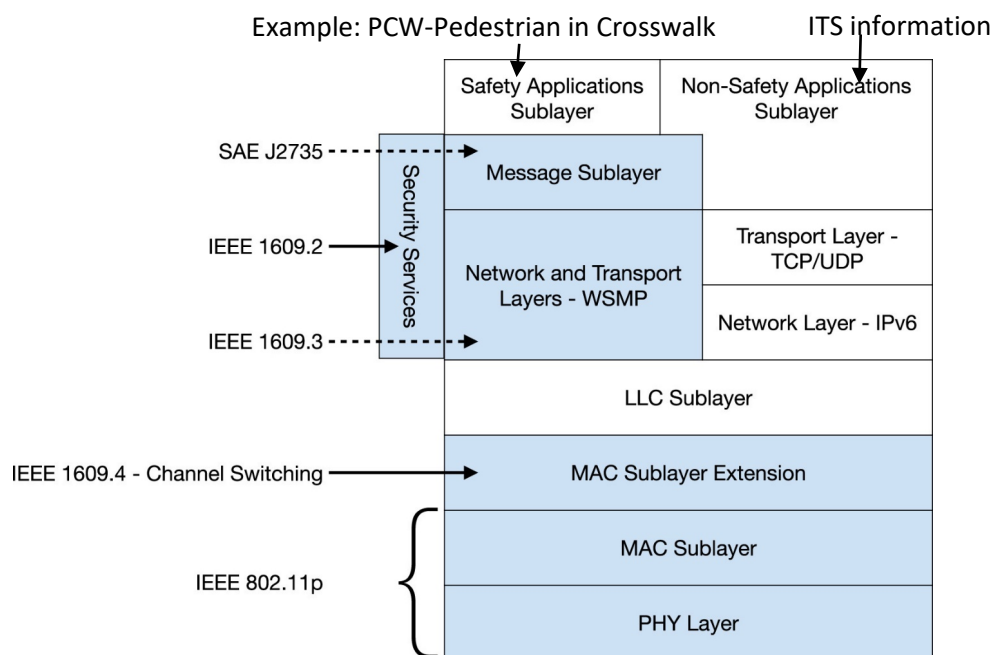

*Wave Short Message (WSM); WAVE Short Message Protocol (WSMP); PHY-Physical Layer  
MAC-Media Access Control; LLC-Logical Link Control*

## 5. Case Studies: Transit CV Safety Applications

The following sample list provides examples of CV transit applications related to transit vehicles operations. Note that US is currently in CV deployment testing phase and limited number of transit applications are being included in testing sites to ascertain efficacy and standards role as well as aftermarket safety devices-ASD/OBU.

**Vehicle Turning Right in Front of Bus Warning (VTRW):** An application that warns transit bus operators of the presence of vehicles attempting to go around the bus to make a right turn as the bus departs from a bus stop.





**Pedestrian in Crosswalk Warning (PCW):** An application that warns transit bus operators when pedestrians, within the crosswalk of a signalized intersection, are in the intended path of the bus. Module presentation covered TRP applications, which covers EPCW (Enhanced PCW), and further details can be found at the following links. PPT presentation included a case study on PCW.

**Transit Signal Priority (TSP) and Freight Signal Priority (FSP):** Two applications that provide signal priority to transit at intersections and along arterial corridors as well as signal priority to freight vehicles along an arterial corridor near a freight facility spot.

**Connection Protection (T-CONNECT):** An application that enables coordination among public transportation providers and travelers to improve the probability of successful transit transfers.

**Dynamic Transit Operations (T-DISP):** An application that links available transportation service resources with travelers through dynamic transit vehicle scheduling, dispatching and routing capabilities.

**Mobile Accessible Pedestrian Signal System (PED-SIG):** An application that allows an automated call from the smart phone of a visually impaired pedestrian to the traffic signal, as well as audio cues to safely navigate the crosswalk.

**Dynamic Ridesharing (D-RIDE):** An application that uses dynamic ridesharing technology, personal mobile devices, and voice activated on-board equipment to match riders and drivers.

**Red Light Violation Warning (RLVW):** An application that broadcasts signal phase and timing (SPat) and other data to the in-vehicle device, allowing warnings for impending red-light violations.

**Curve Speed Warning (CSW):** An application where alerts are provided to the driver who is approaching a curve at a speed that may be too high for safe travel through that curve.

## 6. Glossary

The following are additional **descriptions/acronyms** used in the module.

Term	Definition
Agency Specification	A document that has been prepared by an agency to define requirements for a subject item or process when procured by the agency.
Application	An application process providing application entity functionality as defined by the ITS reference architecture.
ASD-Aftermarket Safety Device	A connected device in a vehicle that operates while the vehicle is mobile, but which is not connected to the data bus of the vehicle. ASD is a connected device, but not integrated during vehicle manufacture but





Term	Definition
	added after sale. It is installed in a vehicle and is capable of sending and receiving messages over a Dedicated Short-Range Communication (DSRC) wireless communications link. The device has a driver interface, runs V2V and V2I safety applications, and issues audible or visual warnings and/or alerts to the driver of the vehicle
Basic Safety Message (BSM)	The message containing the core data set transmitted by the connected vehicle for safety-related purposes (vehicle size, position, speed, heading acceleration, brake system status). The message includes an optional extension that can report additional data depending upon events (e.g., anti-lock brakes activated) but the availability of types of extension data varies by vehicle model. The BSM is tailored for low latency; localized broadcast required by V2V safety applications but can be used with many other types of applications.
Cellular Vehicle-to-Anything	A form of DSRC based on 3GPP LTE technology.
Connected Device	Any device used to transmit or receive messages from another device. Within the scope of V2X, we specifically mean those connected devices that are a part of an ITS trust domain, thereby allowing them to transmit and receive messages with other ITS-trusted connected devices. Within the scope of this course (V2V and V2P), we specifically mean those connected devices that are a part of <i>the</i> ITS trust domain established by the SCMS, thereby allowing them to transmit and receive messages with SCMS-trusted connected devices A connected device can be sub-categorized as an OBU or RSU.
Connected Vehicle (CV)	A vehicle containing an OBU.
Conformance	A condition that exists when an item meets all of the mandatory requirements as defined by a standard. It can be measured on the standard as a whole, which means that it meets all mandatory (and applicable conditional) requirements of the standard or on a feature level (i.e., it conforms to feature X as defined in section X.X.X), which means that it meets all mandatory (and applicable conditional) requirements of the feature.
C-ITS	<p>European Commission in November 2016 adopted a European Strategy on Cooperative Intelligent Transport Systems (C-ITS).</p> <p>C-ITS allows road users and traffic managers to share information and use it to coordinate their actions. This cooperative element – enabled by digital connectivity between vehicles and between vehicles and transport infrastructure – is expected to significantly improve road safety, traffic efficiency and comfort of driving, by helping the driver to take the right decisions and adapt to the traffic situation.</p> <p>Cooperative Intelligent Transport Systems (C-ITS) refers to transport systems, where the cooperation between two or more ITS sub-systems (personal, vehicle, roadside and central) enables and provides an ITS service that offers better quality and an enhanced service level, compared to the same ITS service provided by only one of the ITS sub-systems.</p>
Dedicated Short Range Communications	The use of non-voice radio techniques to transfer data over short distances between roadside and mobile radio units, between mobile units, and between portable and mobile units to perform operations related to the improvement



Term	Definition
(DSRC)	<p>of traffic flow, traffic safety and other intelligent transportation service applications in a variety of public and commercial environments. [FCC, Dedicated Short Range Communications of Intelligent Transportation Services – Final Rule, FR Doc No: 99-30591]</p> <p>A technology for the transmission of information between multiple vehicles (V2V) and between vehicles and the transportation infrastructure (V2I) using wireless technologies.</p> <p>DSRC is also used in US to describe 5.9 GHz spectrum based DSRC.</p>
ITS Station (ITS-S) reference architecture	<p>A reference model to describe how application processes within a device are able to communicate to other devices. The model is defined in ISO 21217 and is based on the ISO Open Systems Interconnect (OSI) Reference Model (ISO 7498-1), but simplifies the OSI model by grouping some layers together and extends the OSI model to explicitly defining the management, application, and security entities that drive communications and provide support functionality to the basic OSI stack.</p>
Interoperability	<p>Degree to which two or more systems, products or components can exchange information and use the information that has been exchanged. [ISO 24765:2017]</p>
Latency	<p>A measure of time delay experienced in a system, the precise definition of which depends on the system and the time being measured. For a data element in this context, latency is the time difference between the time that data value is acquired by the source and the time the message is transmitted.</p>
On-Board Equipment (OBE)	<p>This term refers to the complement of equipment located in the vehicle for supporting the vehicle side of the applications. It is likely to include the DSRC radios, other radio equipment, message processing, driver interface, and other applications to support the use cases described herein. It is also referred to as the Vehicle ITS Station. When referring to the DSRC radio alone, the correct term is OBU (see below).</p>
On-Board Unit (OBU)	<p>A vehicle-mounted device used to transmit and receive a variety of message traffic to and from other connected devices (other OBUs and RSUs). Among the message types and applications supported by this device are vehicle safety messages, a primary subject of this standard, used to exchange information on each vehicle's dynamic movements for coordination and safety.</p>
Public Key Infrastructure (PKI)	<p>A public key infrastructure (PKI) is a set of roles, policies, hardware, software and procedures needed to create, manage, distribute, use, store and revoke digital certificates and manage public-key encryption.</p>
PSID-Provider Service Identifier	<p>A Provider Service Identifier (PSID) is message/application classification; an Organization can request a PSID from IEEE and define and describe how that PS ID is to be used. It is part of the WSMP.</p>
Road-Side Equipment (RSE)	<p>Term used to describe the complement of equipment to be located at the roadside; the RSE will prepare and transmit messages to the vehicles and receive messages from the vehicles for supporting the V2I applications. This is intended to include the DSRC radio, traffic signal controller where appropriate, interface to the backhaul communications network necessary to support the applications, and support such functions as data security, encryption, buffering,</p>



Term	Definition
	and message processing. It may also be referred to as the roadside ITS station. When speaking of the DSRC radio alone, the correct term is RSU (see below).
Roadside Unit (RSU)	A connected device that is only allowed to operate from a fixed position (which may in fact be a permanent installation or from temporary equipment brought on-site for a period of time associated with an incident, road construction, or other event). Some RSEs may have connectivity to other nodes or the Internet.
Security Credential Management System (SCMS)	A public key infrastructure (PKI) approach to security involving the management of digital certificates that are used to sign and authenticate messages that are exchanged among connected devices that might have no direct relationship with each other.
Vehicle-to-Infrastructure (V2I)	The exchange of information between a vehicle and a roadside device or centralized equipment to enhance safety, mobility, and sustainability.
Vehicle-to-Pedestrian (V2P)	The exchange of information between a vehicle and a connected device representing a pedestrian or other vulnerable road user to enhance safety, mobility, and sustainability.
Vehicle-to-Vehicle (V2V)	The exchange of information between vehicles to enhance safety, mobility, and sustainability.
Vehicle-to-Anything (V2X)	The exchange of information between a vehicle one or more connected devices to enhance safety, mobility, and sustainability. The other connected device might be another vehicle, a pedestrian, or other vulnerable road user device, a roadside station, or a central system.
Wireless Access in Vehicular Environments (WAVE)	A radio communications system intended to provide seamless, interoperable services to transportation users.
WAVE Short Message Protocol (WSMP)	A low-overhead Network (TransNet) Layer protocol designed for use over DSRC Wave Short Messages (WSM).

## 7. Acronyms

3GPP	3rd Generation Partnership Project
5G	5 <sup>th</sup> Generation (cellular technology)
ATTRI	Accessible Transportation Technologies Research Initiative
BSM	Basic Safety Message
C-ITS	Cooperative ITS
C-V2X	Cellular Vehicle-to-Anything
CAMP	Collision Avoidance Metrics Partnership
CCH	Control channel
CV	Connected Vehicle
DSRC	Dedicated Short Range Communications
FCC	Federal Communications Commission
FTA	Federal Transit Administration (USDOT agency)



FHWA	Federal Highway Administration (USDOT agency)
IEEE	Institute of Electrical and Electronic Engineers
ISO	International Standards Organization
ITE	Institute of Transportation Engineers
ITS	Intelligent Transportation Systems
LTE	Long-Term Evolution (cellular technology)
NHTSA	National Highway Traffic Safety Administration (USDOT agency)
OBE	On-Board Equipment
OBU	On-Board Units
POC	Proof-of-Concept
PKI	Public Key Infrastructure
PSID	Provider Service Identifier
SAE	Society of Automotive Engineers
SCH	Service channel
SCMS	Security Credential Management System
SDO	Standards Development Organization
USDOT	United States Department of Transportation
V2I	Vehicle-to-Infrastructure
V2P	Vehicle-to-Pedestrian
V2V	Vehicle-to-Vehicle
V2X	Vehicle-to-Anything
WAVE	Wireless Access in Vehicular Environments
WSMP	WAVE Short Message (WSM) Protocol

## 8. References

1. The USDOT's new plan for ITS research and priorities for the second half of the decade  
[https://www.its.dot.gov/research\\_areas/strategicplan2015.htm](https://www.its.dot.gov/research_areas/strategicplan2015.htm)
2. FTA Annual Report on Public Transportation Innovation Research Projects for FY 2018  
<https://www.transit.dot.gov/research-innovation/fta-annual-report-public-transportation-innovation-research-projects-fy-2018>
3. *Infrastructure Initiatives to Apply Connected- and Automated-Vehicle Technology to Roadway Departures*, 2018.  
<https://www.fhwa.dot.gov/publications/research/safety/18035/index.cfm>
4. "Multiple Sources of Safety Information from V2V and V2I: Redundancy, Decision Making, and Trust - Safety Message Design Report," 2015.  
<https://www.fhwa.dot.gov/publications/research/safety/15007/index.cfm>
5. *Status of the Dedicated Short-Range Communications Technology and Applications Report to Congress*  
[https://www.its.dot.gov/research\\_archives/connected\\_vehicle/pdf/DSRCReportCongress\\_FINAL\\_23NOV2015.pdf](https://www.its.dot.gov/research_archives/connected_vehicle/pdf/DSRCReportCongress_FINAL_23NOV2015.pdf)
6. *Dedicated Short-Range Communications (DSRC) Standards in the United States*. John B Kenney, Toyota Motors  
[https://www.researchgate.net/publication/224242297\\_Dedicated\\_Short-Range\\_Communications\\_DSRC\\_Standards\\_in\\_the\\_United\\_States](https://www.researchgate.net/publication/224242297_Dedicated_Short-Range_Communications_DSRC_Standards_in_the_United_States)
7. "Managing DSRC and WAVE Standards Operations in a V2V Scenario." Yasser L. Morgan  
<https://www.hindawi.com/journals/>
8. IEEE 1609 - Family of Standards for Wireless Access in Vehicular Environments (WAVE)  
<https://www.standards.its.dot.gov/Factsheets/Factsheet/80>



9. ASTM E2213-03, Standard Specification for Telecommunications and Information Exchange  
<https://www.astm.org/Standards/E2213.htm>
10. WAVE: Role of IEEE 1609 family- Updated on 20 June 2015  
<https://gauravpathak07.wordpress.com/2015/06/20/wave-brief-role-of-ieee-1609-family/>
11. Wireless Access for Vehicular Environments <https://www.semanticscholar.org/>
12. “Basic Infrastructure Message Development and Standards Support for Connected Vehicles Applications,” 2016.
13. What Is New In ARC-IT <https://local.iteris.com/arc-it/html/whatsnew/whatsnew.html>
14. *Preparing Local Agencies for the Future of Connected and Autonomous Vehicles*. May 2019, <http://www.dot.state.mn.us/research/>
15. Connected Vehicle Applications, USDOT.  
[https://www.its.dot.gov/pilots/cv\\_pilot\\_apps.htm](https://www.its.dot.gov/pilots/cv_pilot_apps.htm)
16. “FTA Connected Vehicle (CV) Project Update,” ITS America Annual Meeting, 2016: presentation handout by Steve Mortensen.  
[https://www.its.dot.gov/pilots/pdf/ITSA2016\\_transitCVprojects\\_Mortensen.pdf](https://www.its.dot.gov/pilots/pdf/ITSA2016_transitCVprojects_Mortensen.pdf)
17. Connected Vehicle Pilot Program USDOT: <https://www.its.dot.gov/pilots/index.htm>
18. Security Credential Management System (SCMS): USDOT  
<https://www.its.dot.gov/resources/scms.htm>
19. MPO Guide for Implementing DSRC Technology in PennDOT District 8-0  
<https://www.tcrpc-pa.org/cmp>
20. Dedicated Short-Range Communications Roadside Unit Specifications  
<https://transportationops.org/publications/dedicated-short-range-communications-roadside-unit-specifications>
21. ITS Standards-USDOT: <https://www.standards.its.dot.gov/Standard/517>
22. 24. “Connected Vehicle (CV) Infrastructure – Urban Bus Operational Safety Platform.” FTA report May 2019  
<https://www.transit.dot.gov/research-innovation/connected-vehicle-cv-infrastructure-%E2%80%93-urban-bus-operational-safety-platform>

## 9. Study Questions

1. Which of the following is an incorrect statement related to CV applications?
  - a) On-Board Unit (OBU) is required for V2V communication.
  - b) Road-Side Unit (RSU) is required for V2I communication.
  - c) ONLY Aftermarket Device (ASD) broadcasts Basic Safety Message (BSM).
  - d) V2X includes all forms of CV communication services.
  
2. Which of the following is NOT a current attribute of DSRC?
  - a) Low latency
  - b) No subscription required
  - c) Widely deployed in vehicles
  - d) Short to medium range



3. Which of the following is NOT a required standard for a Transit Bus Wireless Connectivity?
  - a) IEEE 1609
  - b) SAE J2735
  - c) APTA TCIP
  - d) IEEE 802.11
  
4. Which of the following is not a transit CV application?
  - a) Vehicle turning in Front of Bus Warning (VTRW)
  - b) Enhanced Forward Collision Warning (E-FCW)
  - c) Highway-Rail Grade Crossing
  - d) Transit Signal Priority (TSP)
  
5. Which of the following is (are) a potential barrier to implementation of transit connected vehicles?
  - a) Security
  - b) Privacy
  - c) Evolving standards
  - d) All of the above

## 10. Icon Guide

The following icons are used throughout the module to visually indicate the corresponding learning concept listed out below, and/or to highlight a specific point in the training material.

- 1) **Background information:** General knowledge that is available elsewhere and is outside the module being presented. This will be used primarily in the beginning of slide set when reviewing information readers are expected to already know.



- 2) **Tools/Applications:** An industry-specific item a person would use to accomplish a specific task and applying that tool to fit your need.



- 3) **Remember:** Used when referencing something already discussed in the module that is necessary to recount.



- 4) **Refer to Student Supplement:** Items or information that are further explained/detailed in the Student Supplement.



- 5) **Example:** Can be real-world (case study), hypothetical, a sample of a table, etc.



- 6) **Checklist:** Use to indicate a process that is being laid out sequentially.

