

**Conformance test specifications for
Wireless Access in
Vehicular Environments (WAVE) —
802.11**

Test Suite Structure and Test Purposes (TSS & TP)

Document Mnemonics:	WAVE802.11-TSS&TP
Revision:	[V0.6.0]
Revision Date:	3/24/2016

Table of Contents

1	Scope	4
2	References	4
2.1	Normative References.....	4
2.2	Informative References	4
3	Definitions and abbreviations	4
3.1	Definitions.....	4
3.2	Abbreviations.....	5
4	Prerequisites and Test Configurations	5
4.1	Test Configurations	5
4.1.1	Functional Blocks	8
4.1.2	Test parameters	8
4.2	Feature Restriction	10
4.3	Rules for the behavior description.....	10
4.3.1	States in Initial Conditions	11
5	Test Suite Structure (TSS)	11
5.1	Structure for Network Services tests.....	11
5.1.1	Root	12
5.1.2	Groups.....	12
5.1.3	Sub-Groups	12
5.1.4	Categories	12
6	Test Purposes (TP)	12
6.1	Introduction.....	12
6.1.1	TP definition conventions	12
6.1.2	TP Identifier naming conventions.....	13
6.1.3	Sources of TP definitions	13
6.2	Test purposes for 802.11	14
6.2.1	802.11 Receive MAC Validation.....	14
6.2.2	802.11 Transmit MAC Validation.....	17
6.2.3	802.11 Transmit PHY Validation	18
6.2.4	802.11 Receive PHY Validation	23
	Appendix A: Traceability Matrix	29
	Appendix B: PIXIT proforma	32
	B.1 System Specific Information	32

B.2 Test Purpose Parametric Information..... 32

Revision History..... 38

1 Scope

This document provides the Test Suite Structure and Test Purposes for physical and MAC layers as defined in IEEE 802.11 [2]. This document specifies tests to verify the behavior of MAC frame processing and also to check physical layer characteristics conforming to IEEE 802.11 in a wired environment. Operation in an over-the-air environment is currently out of scope of this document.

The ISO standard for the methodology of conformance testing (ISO/IEC 9646-1 [3] and ISO/IEC 9646-2 [4]) are used as a basis for the test methodology.

2 References

2.1 Normative References

The following referenced documents are necessary for the application of the present document.

- [1] SAE J2945/1 D5.0: "On-board System Requirements for V2V Safety Communications". *Latest draft – will correct final reference when standard is published.*
- [2] IEEE Std. 802.11™-2012: "Part 11: Wireless LAN Medium Access Control (MAC) and Physical Layer (PHY) Specifications".
- [3] ISO/IEC 9646-1 (1994): "Information technology -- Open Systems Interconnection -- Conformance testing methodology and framework - Part 1: General concepts".
- [4] ISO/IEC 9646-2 (1994): "Information technology -- Open Systems Interconnection -- Conformance testing methodology and framework -- Part 2: Abstract Test Suite specification".
- [5] ISO/IEC 9646-7 (1995): "Information technology -- Open Systems Interconnection -- Conformance testing methodology and framework - Part 7: Implementation Conformance Statements".
- [6] Void
- [7] P1609.4™/D5 Draft Standard for Wireless Access in Vehicular Environments – Multi-Channel Operation. *Latest draft – will correct final reference when standard is published.*
- [8] Test System Interface. *Latest draft – will correct final reference when document is reviewed and accepted*

2.2 Informative References

The following referenced documents are not necessary for the application of the present document but they assist the user with regard to a particular subject area.

- [i.1] ETSI EG 202 798 (V1.1.1): "Intelligent Transport Systems (ITS); Testing; Framework for conformance and interoperability testing".

3 Definitions and abbreviations

3.1 Definitions

For the purposes of the present document, the terms and definitions given in IEEE 802.11 [2], ISO/IEC 9646-1 [3] and in ISO/IEC 9646-7 [5] apply.

3.2 Abbreviations

For the purposes of the present document, the following abbreviations apply:

BI	Behavior Invalid
BV	Behavior Valid
CCH	Control Channel
CH	Channel
DSRC	Dedicated Short Range Communications
GPS	Global Positioning System
IEEE	Institute of Electrical and Electronics Engineers
ISO	International Organization for Standardization
ITS	Intelligent Transport Systems
IUT	Implementation Under Test
PC	Computer
PDU	Protocol Data Unit
PER	Packet Error Rate
PLCP	Physical Layer Convergence Procedure
PSDU	PLCP service data unit
RCPI	Received Channel Power Indicator
RF	Radio Frequency
RX	Receive
SA	Signal Analyzer
SAE	Society of Automotive Engineers
SCH	Service Channel
SCMS	Security Credential Management System
TAI	International Atomic Time
TP	Test Purposes
TC	Test Configuration
TS	Test System
TSF	Timing Synchronization Function
TSS	Test Suite Structure
TX or TXT	Transmit
UTC	Coordinated Universal Time
V2V	Vehicle-to-Vehicle
VST	Vector Signal Transceiver
WAVE	Wireless Access in Vehicular Environments
WSM	WAVE Short Message

4 Prerequisites and Test Configurations

4.1 Test Configurations

This clause introduces the test configurations that are used for the definition of test purposes and test descriptions. The test configurations cover the various scenarios of the IEEE 802.11 tests. The Test System setup is implemented according to the figures below. Items such as parasitic power losses as well as minimization of VSWR must be accounted for in any particular test system implementation and are outside the scope of this document.

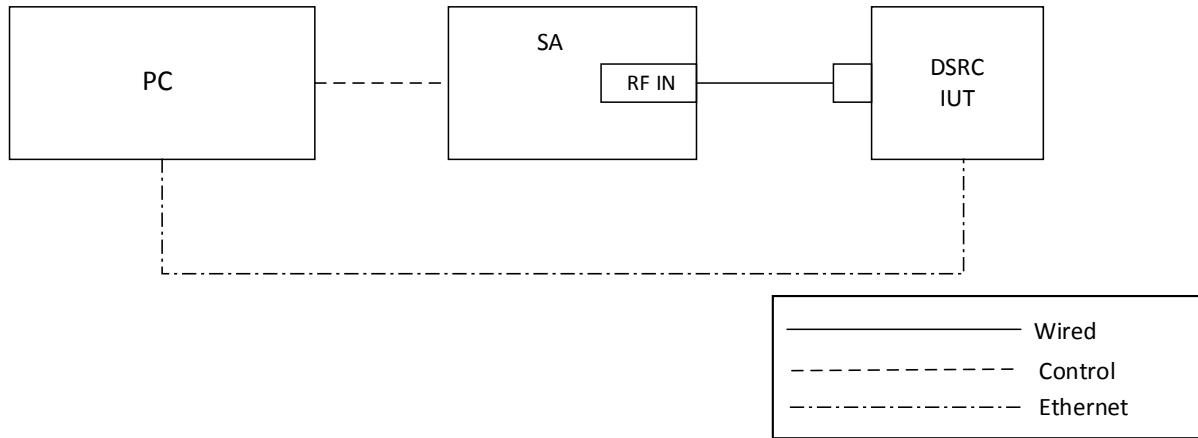

Figure 1: Test Configuration 1 (TC1)

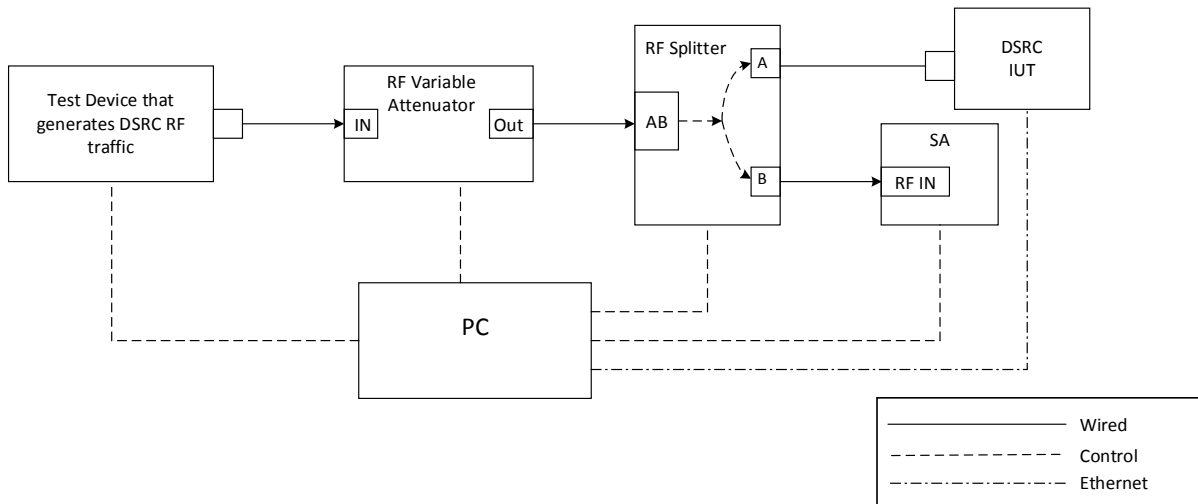

Figure 2: Test Configuration 2 (TC2)

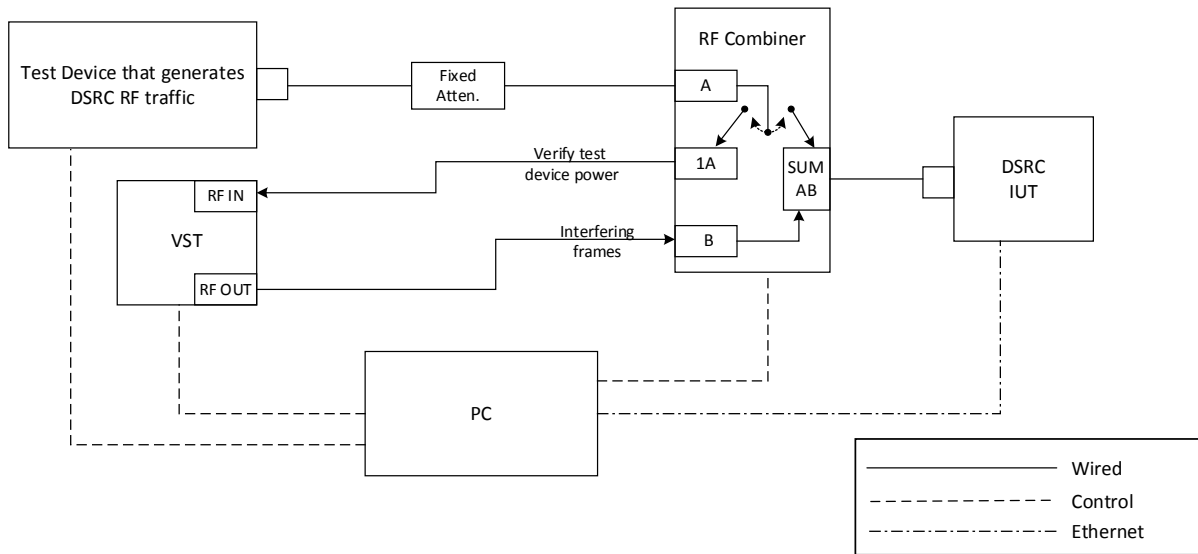

Figure 3: Test Configuration 3 (TC3)

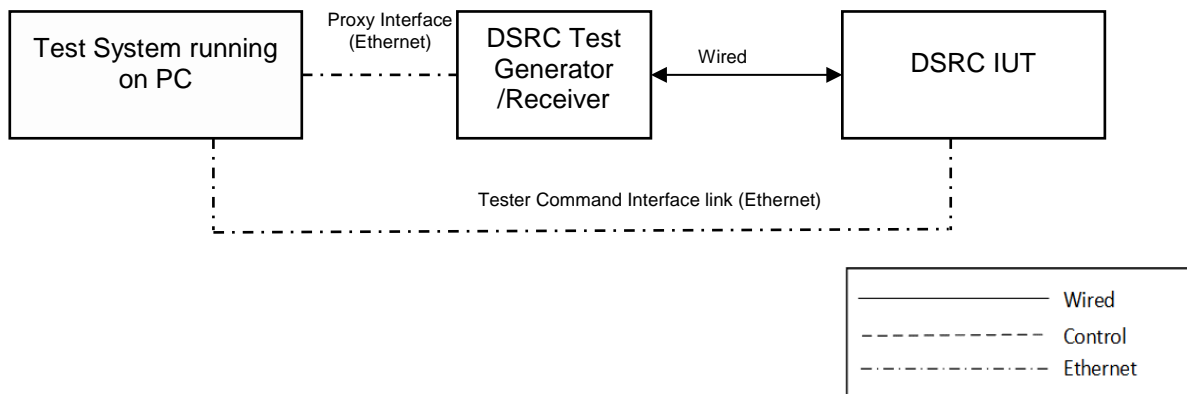

Figure 4: Test Configuration 4 (TC4)

Note: When counting a quantity like Packet Error Rate (PER), if the Implementation Under Test (IUT) does not send an “acknowledgment” then the loss or error count accounts to the corresponding test. This will be the case even if the IUT missed a message because, for whatever reason, the IUT was too busy doing something else.

4.1.1 Functional Blocks

Following are the functional blocks used in the above diagrams.

4.1.1.1 Signal Analyzer

The Signal Analyzer is used to measure various transmit characteristics of the IUT. This may be either a vector signal analyzer or a spectrum analyzer depending on the characteristic being measured including average channel power. In general, a vector signal analyzer can be utilized for all measurements of interest.

4.1.1.2 RF Variable Attenuator

This device provides variable attenuation of an RF signal under the control of the test system / computer.

4.1.1.3 RF Splitter

This device can be utilized to split an RF signal into two separate outputs. This can be used to verify the signal’s power level while transmitting that signal to the IUT.

4.1.1.4 Vector Signal Transceiver (VST)

This device is both a vector signal analyzer and a vector signal generator. It can be used to generate an 802.11 signal of known power level and content, as well as monitor and analyze received 802.11 signals.

4.1.2 Test parameters

Below are listed test parameters / conditions that are applicable to all test cases in this specification.

Note:

- a) All the WSM messages transmitted from IUT will be of a broadcast type unless otherwise specified.
- b) The test procedures which do not have a PIC reference are derived from a requirement.
- c) Tests with 20MHz Channel Spacing are non-mandatory requirements for Connected Vehicle Pilots. In this case *vChannel* will be configured to be 175 and 181.
- d) The test system shall be configured such that all measurements performed on a signal transmitted by the IUT are calibrated to be at the IUT antenna connector of the subsystem housing.
- e) The test system shall be configured such that all RF stimuli applied to the IUT are calibrated such the specified values apply at the IUT antenna connector of the subsystem housing.

4.1.2.1 Channels

Select test values for Channel specified using *vChannel* according to the following table:

Table 4-1: Channels

Parameter Name	Range of Values	Default	Reference
Channels specified as CH1, CH2, <i>vChannel</i>	10MHz channels: 172, 174, 176, 178, 180, 182, 184 20MHz channels: 175, 181	172, 174, etc.	[2], [7]

If requiring more than one channel, set and verify *vChannel* to each supported channel.

4.1.2.2 Data Rate

Select test values for Data Rate specified using *vDataRate* according to the following table.

Parameter Name	Range of Values	Default	Reference
<i>vDataRate</i>	3, 4.5, 6, 9, 12, 18, 24, 27, 36, 48, 54	6	[2]

If requiring more than one data rate, set and verify *vDataRate* to each supported data rate.

4.1.2.3 Tester Transmit Power

For all IUT reception testing, TX power of -30dBm and the minimum sensitivity as per [1] and [2], +/- 1dB (at the IUT's antenna connector) shall be used unless otherwise specified by the respective test purpose.

4.1.2.4 IUT Transmit Power

The transmit power out of the DSRC Radio Subsystem measured at the antenna connector of the Subsystem housing shall be within a range of *MaxTxPowerCap - PwrRange* to *MaxTxPowerCap* [1].

4.1.2.5 Timeout

The TIMEOUT interval is 100ms unless otherwise specified.

Rationale: This is two times the channel switching interval.

4.1.2.6 Packet Size

For all IUT reception testing, the test equipment transmits packets with a length of 400 octets with any valid value as per [1].

4.1.2.7 PER

IUT receive Packet Error Rate (PER) should be 10% or less at -30 dBm according to SAE J2945/1 [1].

Test Equipment assumes maximum receive PER of 10% at -30 dBm.

4.1.2.8 Number of Frames

Select test values for number of frames specified using *vNumberOfFrames* for test purposes as shown in table below:

Table 4-3: Number of Frames

Parameter Name	Test Purpose	Value	Comment
<i>vNumberOfFrames</i>	TP-80211-TXT-PHY-BV-01 to TP-80211-TXT-PHY-BV-07	64	This value is a recommended value. The tests shall have a 95% confidence level of +/- 1 dB which will determine the actual value used.
<i>vNumberOfFrames</i>	TP-80211-RXT-PHY-BV-05	64	This value is a recommended value. The tests shall have a 95% confidence level of +/- 5 dB.
<i>vNumberOfFrames</i>	TP-80211-RXT-PHY-BV-01 to TP-80211-RXT-PHY-BV-04	1000	This value is a recommended value. The tests shall determine the PER and make the Pass/Fail determination with a 95% confidence level.

4.1.2.9 Other parameters

The rationale for parameters *vTxPwrAcc*, *MaxTxPowerCap*, *PwrRange*, *vTxPwrCtrlStep* used in this document is as specified in SAE J2945/1 [1].

PwrRange will need to be provided with the IUT by the test requestor.

4.2 Feature Restriction

The following are current feature restrictions:

- For multiple radio devices only one radio is tested at a time.
- Simultaneous operation of DSRC device on Control Channel (CCH) and Service Channel (SCH) for multi-radio devices is not considered
- Immediate access or extended access to communication media is not considered
- Channel Load is not tested
- User Priorities are not tested
- Timing Synchronization Function (TSF) accuracy is not tested.
- Service Access Points (SAP) are not tested
- Congestion control is not considered

4.3 Rules for the behavior description

Test purposes use a generic "Initial State" that corresponds to a state where the IUT is ready for starting the test execution. Furthermore, the IUT shall be left in this "Initial State", when the test is completed.

Being in the "Initial State" refers to the starting point of the initial device configuration. There are no pending actions, no instantiated buffers or variables, which could disturb the execution of a test.

4.3.1 States in Initial Conditions

Overall state diagram for a test system is shown below.

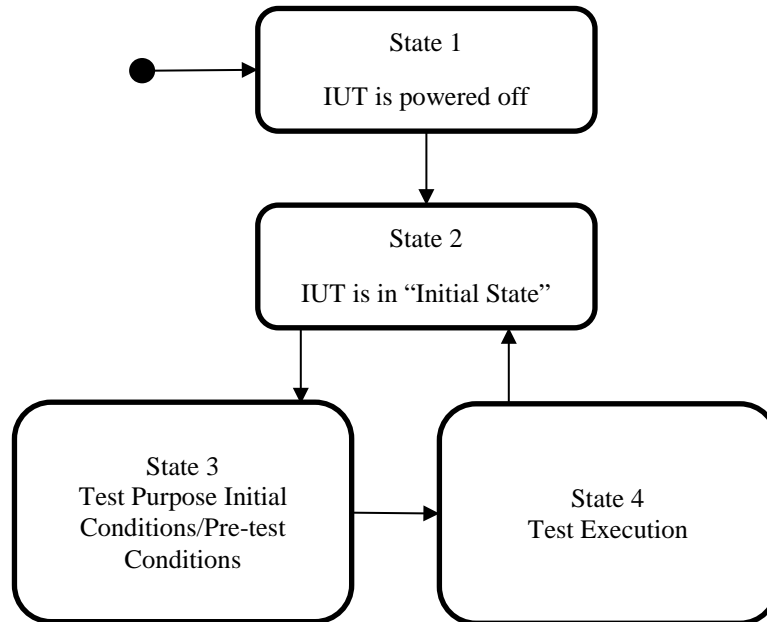

Each TP contains an initial condition. The initial condition defines the initial state in which the IUT has to be to apply the actual TP. Most of the TPs start from the “initial state” which is defined as follows:

- Test Environment and Test System has reached room temperature (21 degrees Celsius +/- 5 degrees).
- The IUT is polled until the device is ready for operation.
- The IUT is not transmitting or receiving messages over DSRC link.
- The IUT is not exchanging any IP traffic
- The IUT is provisioned with any required security credentials to enable transmission or reception of messages over DSRC.
- The IUT is running Certification Interface Application [8].

Certificate Interface Application acts as an interface between IUT and Test System which defines a message protocol to simulate valid and invalid protocol behaviors and helps in analyzing the reaction of IUT.

Some TPs start from a different initial condition which is explicitly defined in the TP. However, the “initial state” defined above is the starting point before the different initial conditions are established.

When the execution of the initial condition does not succeed, the test verdict is said to fail and testing is halted.

5 Test Suite Structure (TSS)

5.1 Structure for Network Services tests

The test suite is structured as a tree with the root defined as 80211. The tree is of rank 3 with the first rank a Group, the second a Sub-group, and the third a category. The third rank is the standard ISO conformance test categories.

5.1.1 Root

The root consists of the relevant clauses of IEEE 802.11 [2] as indicated by the References and PIC Selections in the individual Test Purposes (section 6 of this document).

5.1.2 Groups

This level contains three message types identified as:

Transmit (TX) tests

Receive (RX) tests

5.1.3 Sub-Groups

This level contains functional areas identified as:

RF and Physical Layer tests

MAC frame tests

5.1.4 Categories

This level contains the standard ISO conformance test categories limited to the behavior valid event and behavior invalid event.

6 Test Purposes (TP)

6.1 Introduction

6.1.1 TP definition conventions

The TPs are defined by the rules shown in Table 6-1 built according to EG 202 798 [i.1].

Table 6-1: TP definition rules

Test Purpose ID	The Test Purpose ID is a unique identifier. It shall be specified according to the TP naming conventions defined in the clause below.
Summary	Short description of test purpose objective according to the requirements from the base standard.
References	The reference indicates the sub-clauses of the reference standard specifications in which the conformance requirement is expressed.
Test Configuration	The Config Id references the test configuration selected for this TP.
PICS Selection	Reference to the PICS statement involved for selection of the TP. It may contain a Boolean expression.
Pre-Test Conditions	A list of test specific pre-conditions that need to be met by the IUT including information about equipment configuration, i.e. precise description of the initial state of the IUT required to start executing the test sequence
Test Sequence	An ordered list of equipment operation and observations. In case of a conformance test description the test sequence contains also the conformance checks as part of the observations
Event Types	
Stimulus	Corresponds to an event that forces an IUT to proceed with a specific protocol action, like sending a message for instance.
Verify	Consists of verifying that the IUT behaves according to the expected behavior (for instance the IUT behavior shows that it receives the expected message).

Configure	Corresponds to an action to modify the IUT configuration.
Procedure	Procedural action directing the flow of TP execution.

6.1.2 TP Identifier naming conventions

TP identifiers are built according to Table 6-2.

Table 6-2: TP naming convention

Identifier	TP- <root> - <gr> - <sgr> - <x> - <nn> or TP- <root> - <gr> - <x> - <nn> when no <sgr>		
	<root> = root	80211	
	<gr> = group	RXT	Receive
		TXT	Transmit
	<sgr> =sub- group	MAC	Medium Access Control Layer
		PHY	Physical Layer
		BV	Valid Behavior tests
	<x> = type of testing	BI	Invalid Syntax or Behavior Tests
	<nn> = sequential number		01 to 99

6.1.3 Sources of TP definitions

All TPs are specified according to IEEE 802.11 [2] and SAE J2945/1 [1]. Traceability from PICS to TPs is included in Appendix A.

Appendix A includes a list of PICS from IEEE 802.11 relevant to this document. SAE J2945/1 [1] uses a subset of PICS from IEEE 802.11. Those PICS are identified with status V2V and SCMS.

6.2 Test purposes for 802.11

6.2.1 802.11 Receive MAC Validation

6.2.1.1 TP-80211-RXT-MAC-BV-01

Test Purpose Id	TP-80211-RXT-MAC-BV-01		
Summary	Transmit WSM to IUT with MAC field values as per J2945/1 V5, Table 5 (section 8.3.2.1) and verify that IUT receives a frame.		
Test Configuration	TC4		
Reference:	[1] Table 5, Clause: 8.3.2.1		
PICS Selection	PC8, AD2, AD3, AD4, FR18		
Pre-test conditions			
<ul style="list-style-type: none"> The IUT is in initial state as per sec 4.3.1 			
Test Sequence			
Step	Type	Description	Verdict
1	Configure	IUT as receiver on <i>vChannel</i>	
2	Configure	Test Equipment as transmitter on <i>vChannel</i> and <i>vDataRate</i>	
3	Configure	<p>The Test Equipment to transmit WSMs at a nominal rate of 10 messages per second with MAC header containing the field values as listed below.</p> <p>Frame Control containing:</p> <ul style="list-style-type: none"> Protocol version (bits 0-1) = 00; Type (bits 2-3) = 10; Subtype (bits 4-7) = 1000; ToDS (bit 8) = 0; FromDS (bit 9) = 0; More Fragments (bit 10) = 0; Retry (bit 11) = 0; Power Management (bit 12) = 0; More Data (bit 13) = 0; Protected Frame (bit 14) = 0; Order (bit 15) = 0; <p>Duration ID = 0</p> <p>Address 1 (destination) = 0xFF:FF:FF:FF:FF:FF</p> <p>Address 2 (source) = random 6 Octets</p> <p>Address 3 (BSS ID) = 0xFF:FF:FF:FF:FF:FF</p> <p>Sequence control containing:</p> <ul style="list-style-type: none"> Fragment number = 0; Sequence number = {incrementing number per frame}. <p>QoS control containing:</p> <ul style="list-style-type: none"> TID (bits 0-3) = 0-7 {user priority value}; EOSP (bit 4) = 0; Ack Policy: bit 5 = 1, bit 6 = 0 (No ACK); A-MSDU Present (bit 7) = 0; TxOP Duration Req (bits 8-15) = 0. 	
4	Stimulus	The Test Equipment to transmit.	

5	Verify	The IUT receives a WSM.	PASS / FAIL
6	Procedure	Repeat steps 2-5 for each supported value of <i>vDataRate</i> in Table 4-2	
7	Procedure	Repeat steps 1-6 for each supported value of <i>vChannel</i> in Table 4-1	
8	Configure	The IUT to initial state	

6.2.1.2 TP-80211-RXT-MAC-BI-01

Test Purpose Id	TP-80211-RXT-MAC-BI-01		
Summary	Transmit WSMs with MAC field values other than those specified in J2945/1 V5, Table 5 (section 8.3.2.1) and verify that the IUT rejects the frames.		
Test Configuration	TC4		
Reference:	[1] Table 5, Clause: 8.3.2.1		
PICS Selection	PC8, AD2, AD3, FR18, AD4		
Pre-test conditions			
<ul style="list-style-type: none"> The IUT is in initial state as per sec 4.3.1 			
Test Sequence			
Step	Type	Description	Verdict
1	Configure	IUT as receiver on <i>vChannel</i>	
2	Configure	Test Equipment as transmitter on <i>vChannel</i> and <i>vDataRate</i>	
3	Configure	Test equipment to transmit WSMs continuously with frame control field from B8-B15 set to 0.	
4	Stimulus	The test equipment to transmit.	
5	Verify	The IUT receives a frame.	PASS / FAIL
6	Configure	The test equipment to transmit 10WSMs with frame control field from B8-B15 set to 1.	
7	Stimulus	The test equipment to transmit.	
8	Verify	The IUT rejects all frames.	PASS / FAIL
9	Procedure	Repeat steps 3-8 with B8-B15 in step 6 set to each value from 2 through 255	
10	Procedure	Repeat steps 2-9 for each supported value of <i>vDataRate</i> in Table 4-2	
11	Procedure	Repeat steps 1-10 for each supported value of <i>vChannel</i> in Table 4-1	
12	Configure	The IUT to initial state	

6.2.1.3 TP-80211-RXT-MAC-BI-02

Test Purpose Id	TP-80211-RXT-MAC-BI-02		
Summary	Transmit WSMs with “Address1” and “Address3” fields in MAC frame other than specified in J2945/1 V5, Table 5 (section 8.3.2.1) and verify that the IUT rejects the frames.		
Test Configuration	TC4		
Reference:	[1] Table 5, Clause: 8.3.2.1		
PICS Selection	PC8, AD2, AD3, FR18, AD4		
Pre-test conditions			
<ul style="list-style-type: none"> The IUT is in initial state as per sec 4.3.1 			
Test Sequence			
Step	Type	Description	Verdict
1	Configure	IUT as receiver on <i>vChannel</i>	
2	Configure	Test Equipment as transmitter on <i>vChannel</i> and <i>vDataRate</i>	
3	Configure	The test equipment to transmit WSMs continuously with “Address1” and “Address3” fields in MAC frame as below: Address1 (destination) – FF:FF:FF:FF:FF:FF	

		Address3 (BSSID) –FF:FF:FF:FF:FF:FF	
4	Stimulus	The test equipment to transmit.	
5	Verify	The IUT receives a frame.	PASS / FAIL
6	Configure	The test equipment to transmit 10WSMs with “Address1” and “Address3” fields in MAC frame as below: Address1 (destination) –AA:FF:FF:FF:FF:FF Address3 (BSSID) – FF:FF:FF:FF:FF:FF	
7	Stimulus	The test equipment to transmit.	
8	Verify	The IUT rejects all frames.	PASS / FAIL
9	Procedure	Repeat steps 3-8 by changing “Address1” and “Address3” in step 6 to each value listed in Invalid MAC address table.	
10	Procedure	Repeat steps 2-9 for each supported value of <i>vDataRate</i> in Table 4-2	
11	Procedure	Repeat steps 1-10 for each supported value of <i>vChannel</i> in Table 4-1	
12	Configure	The IUT to initial state	

Invalid MAC address table

ADDRESS 1 (all values hex)						ADDRESS 3 (all values hex)					
Byte 1	Byte 2	Byte 3	Byte 4	Byte 5	Byte 6	Byte 1	Byte 2	Byte 3	Byte 4	Byte 5	Byte 6
FF	AA	FF	FF	FF	FF	FF	FF	FF	FF	FF	FF
FF	FF	AA	FF	FF	FF	FF	FF	FF	FF	FF	FF
FF	FF	FF	AA	FF	FF	FF	FF	FF	FF	FF	FF
FF	FF	FF	FF	AA	FF	FF	FF	FF	FF	FF	FF
FF	FF	FF	FF	FF	AA	FF	FF	FF	FF	FF	FF
FF	FF	FF	FF	FF	FF	AA	FF	FF	FF	FF	FF
FF	FF	FF	FF	FF	FF	FF	AA	FF	FF	FF	FF
FF	FF	FF	FF	FF	FF	FF	FF	AA	FF	FF	FF
FF	FF	FF	FF	FF	FF	FF	FF	FF	AA	FF	FF
FF	FF	FF	FF	FF	FF	FF	FF	FF	FF	AA	FF
FF	FF	FF	FF	FF	FF	FF	FF	FF	FF	FF	AA

6.2.1.4 TP-80211-RXT-MAC-BV-02

Test Purpose Id	TP-80211-RXT-MAC-BV-02		
Summary	Transmit WSMs to IUT with static MAC address and verify frames are received by the IUT.		
Test Configuration	TC4		
Reference:	[2] Section 8.2.4.3.8		
PICS Selection	AD3, AD4		
Pre-test conditions			
<ul style="list-style-type: none"> The IUT is in initial state as per sec 4.3.1 			
Test Sequence			
Step	Type	Description	Verdict
1	Configure	IUT as receiver on <i>vChannel</i>	

2	Configure	Test Equipment as transmitter on <i>vChannel</i> and <i>vDataRate</i>	
3	Configure	The test equipment to transmit WSMs at a nominal rate of 10 messages per second with a static MAC address as below: Address2(source) = BF:F3:F2:65:BD:44	
4	Stimulus	The test equipment to transmit.	
5	Verify	The IUT receives a WSM.	PASS / FAIL
6	Procedure	Repeat steps 2-5 for each supported value of <i>vDataRate</i> in Table 4-2	
7	Procedure	Repeat steps 1-6 for each supported value of <i>vChannel</i> in Table 4-1	
8	Configure	The IUT to initial state	

6.2.2 802.11 Transmit MAC Validation

6.2.2.1 TP-80211-TXT-MAC-BV-01

Test Purpose Id		TP-80211-TXT-MAC-BV-01	
Summary		Transmit WSM from IUT and verify 802.11 QoS MAC formats and MAC field values	
Test Configuration		TC4	
Reference:		[1] Table 5, Clause: 8.3.2.1	
PICS Selection		PC8, AD2, AD3, AD4, FT18	
Pre-test conditions			
<ul style="list-style-type: none"> IUT is in initial state as per sec 4.3.1 			
Test Sequence			
Step	Type	Description	Verdict
1	Configure	The Test Equipment to receive packets on <i>vChannel</i>	
2	Configure	The IUT as transmitter on <i>vChannel</i> and <i>vDataRate</i>	
3	Stimulus	The IUT to send periodic WSMs.	
4	verify	<p>The IUT sent a WSM with MAC header containing the following field values:</p> <p>Frame Control containing:</p> <ul style="list-style-type: none"> Protocol version (bits 0-1) = 00; Type (bits 2-3) = 10; Subtype (bits 4-7) = 1000; ToDS (bit 8) = 0; FromDS (bit 9) = 0; More Fragments (bit 10) = 0; Retry (bit 11) = 0; Power Management (bit 12) = 0; More Data (bit 13) = 0; Protected Frame (bit 14) = 0; Order (bit 15) = 0 <p>Duration ID = 0</p> <p>Address 1 (destination) = 0xff:ff:ff:ff:ff:ff</p> <p>Address 3 (BSS ID) = 0xff:ff:ff:ff:ff:ff</p> <p>Sequence control containing:</p> <ul style="list-style-type: none"> Fragment number = 0; Sequence number = {incrementing number per frame}. 	PASS / FAIL

		QoS control containing: <ul style="list-style-type: none"> • TID (bits 0-3) = 0-7{user priority}; • EOSP (bit 4) = 0; • Ack Policy: bit 5 = 1, bit 6 = 0 (No ACK); • A-MSDU Present (bit 7) = 0; • TxOP Duration Req (bits 8-15) = 0. 	
5	Procedure	Repeat steps 2-4 for each supported value of <i>vDataRate</i> in Table 4-2	
6	Procedure	Repeat steps 1-5 for each supported value of <i>vChannel</i> in Table 4-1	
7	Configure	The IUT to initial state	

6.2.3 802.11 Transmit PHY Validation

6.2.3.1 TP-80211-TXT-PHY-BV-01

Test Purpose Id	TP-80211-TXT-PHY-BV-01		
Summary	Verify Transmit spectral mask using spectrum analyzer during IUT transmission		
Test Configuration	TC1		
Reference:	[2] Clause 18, 18.3.9.3, Annex D.2, D.2.4		
PICS Selection	OF4.15, OF4.15.3, OF4.15.4		
Pre-test conditions			
<ul style="list-style-type: none"> • A Signal Analyzer is available and is configured to capture signals on DSRC channels as per [2] clause 18.3.9.3; • The IUT is in initial state as per sec 4.3.1 			
Test Sequence			
Step	Type	Description	Verdict
1	Configure	The IUT to send frames at a rate of one every 100 msecs on <i>vChannel</i> and <i>vDataRate</i> at a power of (<i>MaxTxPowerCap</i> - <i>PwrRange</i>).	
2	Stimulus	The IUT to transmit frames.	
3	Verify	The Signal Analyzer captures <i>vNumberOfFrames</i> frames and computes the Average Spectral Mask of transmitted waveform containing the Power Spectral Density of the emissions attenuated below the output power of the transmitter as given in [2] Annex D, Table D-5(STA transmit power class C).	PASS / FAIL
4	Verify	The transmit power out of the DSRC Radio Subsystem as measured at the antenna connector of the Subsystem housing is within <i>vTxPwrAcc</i> of its expected value over 95% of test measurements at each transmit power step.	PASS/FAIL
5	Procedure	Repeat steps 1-4 with increasing power levels in increments of <i>vTxPowerCtrlStep</i> to <i>MaxTxPowerCap</i> .	
6	Procedure	Repeat steps 1-5 for each supported value of <i>vDataRate</i> in Table 4-2	
7	Procedure	Repeat steps 1-6 for each supported value of <i>vChannel</i> in Table 4-1	
8	Configure	The IUT to initial state	

6.2.3.2 TP-80211-TXT-PHY-BV-02

Test Purpose Id	TP-80211-TXT-PHY-BV-02		
Summary	Verify center frequency tolerance of IUT is within conformance limit		
Test	TC1		

Configuration			
Reference:		[2] Clause 18, 18.3.9.5	
PICS Selection		OF4.4	
Pre-test conditions			
<ul style="list-style-type: none"> A Signal Analyzer is available and is configured to capture signals on DSRC channels as per [2] clause 18.3.9.5; The IUT is in initial state as per sec 4.3.1 			
Test Sequence			
Step	Type	Description	Verdict
1	Configure	The IUT to send frames at a rate of one every 100msecs with <i>vChannel</i> and <i>vDataRate</i> at a power of (<i>MaxTxPowerCap</i> - <i>PwrRange</i>)	
2	Stimulus	The IUT to transmit frames.	
3	Verify	The signal analyzer captures <i>vNumberOfFrames</i> frames and computes the average center frequency tolerance over the entire packet for all messages indicating transmit center frequency tolerance not exceeding +/-20ppm.	PASS / FAIL
4	Verify	The transmit power out of the DSRC Radio Subsystem as measured at the antenna connector of the Subsystem housing is within <i>vTxPwrAcc</i> of its expected value over 95% of test measurements at each transmit power step.	PASS/FAIL
5	Procedure	Repeat steps 1-4 with increasing power levels in increments of <i>vTxPowerCtrlStep</i> to <i>MaxTxPowerCap</i> .	
6	Procedure	Repeat steps 1-5 for each supported value of <i>vDataRate</i> in Table 4-2	
7	Procedure	Repeat steps 1-6 for each supported value of <i>vChannel</i> in Table 4-1	
8	Configure	The IUT to initial state	

6.2.3.3 TP-80211-TXT-PHY-BV-03

Test Purpose Id		TP-80211-TXT-PHY-BV-03	
Summary		Verify symbol clock frequency tolerance of IUT is within conformance limit	
Test Configuration		TC1	
Reference:		[2] Clause 18, 18.3.9.6	
PICS Selection		OF4.5	
Pre-test conditions			
<ul style="list-style-type: none"> A Signal Analyzer is available and is configured to capture signals on DSRC channels as per [2] clause 18.3.9.6; The IUT is in initial state as per sec 4.3.1 			
Test Sequence			
Step	Type	Description	Verdict
1	Configure	The IUT to send frames at a rate of one every 100msecs with <i>vChannel</i> and <i>vDataRate</i> at a power of (<i>MaxTxPowerCap</i> - <i>PwrRange</i>)	
2	Stimulus	The IUT to transmit frames.	
3	Verify	The signal analyzer captures <i>vNumberOfFrames</i> frames and computes the average symbol clock frequency tolerance over the entire packet for all messages indicating symbol clock frequency tolerance not exceeding +/-20ppm.	PASS / FAIL
4	Verify	The transmit power out of the DSRC Radio Subsystem as measured at the antenna connector of the Subsystem housing is within <i>vTxPwrAcc</i> of its expected value over 95% of test measurements at each transmit power step.	PASS/FAIL
5	Procedure	Repeat steps 1-4 with increasing power levels in increments of <i>vTxPowerCtrlStep</i> to <i>MaxTxPowerCap</i> .	
6	Procedure	Repeat steps 1-5 for each supported value of <i>vDataRate</i> in Table 4-2	
7	Procedure	Repeat steps 1-6 for each supported value of <i>vChannel</i> in Table 4-1	

8	Configure	The IUT to initial state	
---	-----------	--------------------------	--

6.2.3.4 TP-80211-TXT-PHY-BV-04

Test Purpose Id		TP-80211-TXT-PHY-BV-04		
Summary		Verify the relative constellation RMS error and transmit modulation accuracy of IUT is within conformance limit		
Test Configuration		TC1		
Reference:		[2] Clause 18, 18.3.9.7.4, 18.3.9.8		
PICS Selection		OF4.6.3, OF4.6.4, OF4.6.5, OF4.6.6, OF4.6.7, OF4.6.8, OF4.6.9, OF4.6.10;		
Pre-test conditions				
<ul style="list-style-type: none"> A Signal Analyzer is available and is configured to capture signals on DSRC channels with the capability as specified in [2] clause 18.3.9.8 The IUT is in initial state as per sec 4.3.1 				
Test Sequence				
Step	Type	Description		Verdict
1	Configure	The IUT to send frames at a rate of one every 100msecs with random data on <i>vChannel</i> and <i>vDataRate</i> at a power of (<i>MaxTxPowerCap</i> - <i>PwrRange</i>).		
2	Stimulus	The IUT to transmit frames.		
3	Verify	The Signal Analyzer captures <i>vNumberOfFrames</i> frames, demodulates the signal and computes EVM indicating value not greater than the values as shown in table below.		PASS / FAIL
4	Verify	The transmit power out of the DSRC Radio Subsystem as measured at the antenna connector of the Subsystem housing is within <i>vTxPwrAcc</i> of its expected value over 95% of test measurements at each transmit power step.		PASS/FAIL
5	Procedure	Repeat steps 1-4 with increasing power levels in increments of <i>vTxPowerCtrlStep</i> to <i>MaxTxPowerCap</i> .		
6	Procedure	Repeat steps 1-5 for each supported value of <i>vDataRate</i> in Table 4-2		
7	Procedure	Repeat steps 1-6 for each supported value of <i>vChannel</i> in Table 4-1		
8	Configure	The IUT to initial state		
Relative Constellation Error Table Vs Data Rate				
Coding Rate	Modulation	Date Rate (MBPS)	Relative Constellation Error (dB)	Error Vector Magnitude (EVM) (% RMS)
½	BPSK	3	-5	56.2
¾	BPSK	4.5	-8	39.8
½	QPSK	6	-10	31.6
¾	QPSK	9	-13	22.3
½	16-QAM	12	-16	15.8
¾	16-QAM	18	-19	11.2
² / ₃	64-QAM	24	-22	7.9
¾	64-QAM	27	-25	5.6

6.2.3.5 TP-80211-TXT-PHY-BV-05

Test Purpose Id	TP-80211-TXT-PHY-BV-05		
Summary	Verify the observed power is within spectral flatness conformance limits.		
Test Configuration	TC1		
Reference:	[2] Clause 18, 18.3.9.7.3		
PICS Selection	OF4.6.2		
Pre-test conditions			
<ul style="list-style-type: none"> A Signal Analyzer is available and is configured to capture signals on DSRC channels with the capability as specified in [2] clause 18.3.9.8; The IUT is in initial state as per sec 4.3.1 			
Test Sequence			
Step	Type	Description	Verdict
1	Configure	The IUT to send frames at a rate of one every 100 msec with <i>vChannel</i> and <i>vDataRate</i> at a power of (<i>MaxTxPowerCap</i> - <i>PwrRange</i>).	
2	Stimulus	The IUT to transmit frames.	
3	Verify	The Signal Analyzer captures <i>vNumberOfFrames</i> frames and observes energy magnitude in each subcarrier of the demodulated long training symbols to be as part of Average Energy Deviation Table as shown below.	PASS / FAIL
4	Verify	The transmit power out of the DSRC Radio Subsystem as measured at the antenna connector of the Subsystem housing is within <i>vTxPwrAcc</i> of its expected value over 95% of test measurements at each transmit power step.	PASS/FAIL
5	Procedure	Repeat steps 1-4 with increasing power levels in increments of <i>vTxPowerCtrlStep</i> to <i>MaxTxPowerCap</i> .	
6	Procedure	Repeat steps 1-5 for each supported value of <i>vDataRate</i> in Table 4-2	
7	Procedure	Repeat steps 1-6 for each supported value of <i>vChannel</i> in Table 4-1	
8	Configure	The IUT to initial state	
Average Energy Deviation Table			
	SubCarrier	Energy Limit	
	-16 to -1	within (average energy \pm 4 dB)	
	+1 to +16	within (average energy \pm 4 dB)	
	-26 to -17	within (average energy for -16 to -1 or +1 to +16) +4/-6 dB	
	+17 to +26	within (average energy for -16 to -1 or +1 to +16) +4/-6 dB	

6.2.3.6 TP-80211-TXT-PHY-BV-06

Test Purpose Id	TP-80211-TXT-PHY-BV-06		
Summary	Verify transmitter center frequency leakage is within conformance limits.		
Test Configuration	TC1		
Reference:	[2] Clause 18, 18.3.9.7.2		
PICS Selection	OF4.6.1		
Pre-test conditions			
<ul style="list-style-type: none"> A Signal Analyzer is available and is configured to capture signals on DSRC channels with the capability as specified in [2] clause 18.3.9.8; The IUT is in initial state as per sec 4.3.1 			
Test Sequence			
Step	Type	Description	Verdict
1	Configure	The IUT to send frames at a rate of one every 100msecs with <i>vChannel</i> and <i>vDataRate</i> at a power of (<i>MaxTxPowerCap</i> - <i>PwrRange</i>).	
2	Stimulus	The IUT to transmit frames	
3	Verify	The Signal Analyzer captures <i>vNumberOfFrames</i> frames and computes signal at center frequency such that average power at center frequency shall not exceed overall transmit power of -15dB or value shall not exceed the average energy of rest of the sub carriers +2dB.	PASS / FAIL
4	Verify	The transmit power out of the DSRC Radio Subsystem as measured at the antenna connector of the Subsystem housing is within <i>vTxPwrAcc</i> of its expected value over 95% of test measurements at each transmit power step.	PASS/FAIL
5	Procedure	Repeat steps 1-4 with increasing power levels in increments of <i>vTxPowerCtrlStep</i> to <i>MaxTxPowerCap</i> .	
6	Procedure	Repeat steps 1-5 for each supported value of <i>vDataRate</i> in Table 4-2	
7	Procedure	Repeat steps 1-6 for each supported value of <i>vChannel</i> in Table 4-1	
8	Configure	The IUT to initial state	

6.2.3.7 TP-80211-TXT-PHY-BV-07

Test Purpose Id	TP-80211-TXT-PHY-BV-07		
Summary	Verify transmitter power is a monotonically increasing function of <i>vTxPwrCtrlStep</i> .		
Test Configuration	TC1		
Reference:	[1] 6.4.1.1, [6.4.1-V2V-RFPERF-DSRCTX-004]		
PICS Selection			
Pre-test conditions			
<ul style="list-style-type: none"> The IUT is in initial state as per sec 4.3.1 A Signal Analyzer is available and is configured to capture signals on DSRC channels with the capability as specified in clause 18.3.9.8 [2] 			
Test Sequence			
Step	Type	Description	Verdict
1	Configure	The IUT to send frames at a rate of one every 100msecs with <i>vChannel</i> and <i>vDataRate</i> at a power of (<i>MaxTxPowerCap</i> - <i>PwrRange</i>)	
2	Stimulus	The IUT to transmit frames.	
3	Verify	The Signal Analyzer captures <i>vNumberOfFrames</i> frames and computes transmit power such that the transmit power out of the DSRC Radio Subsystem measured at the antenna connector of the Subsystem housing shall be within <i>vTxPwrAcc</i> of its setting over 95% of test measurements at each setting within the range (<i>MaxTxPowerCap</i> - <i>PwrRange</i>)	PASS/FAIL
4	Procedure	Repeat steps 1-3 with increasing power levels in increments of <i>vTxPowerCtrlStep</i> to <i>MaxTxPowerCap</i> .	

5	Procedure	Repeat steps 1-4 for each supported value of <i>vDataRate</i> in Table 4-2	
6	Procedure	Repeat steps 1-5 for each supported value of <i>vChannel</i> in Table 4-1	
7	Configure	The IUT to initial state	

6.2.4 802.11 Receive PHY Validation

6.2.4.1 TP-80211-RXT-PHY-BV-01

Test Purpose Id		TP-80211-RXT-PHY-BV-01	
Summary		Verify the receiver can operate at the specified minimum input sensitivity depending on the channel spacing and number.	
Test Configuration		TC2	
Reference:		[2] Clause 18, 18.3.10.2	
PICS Selection		OF2.1, OF2.21, OF5.1, OF5.1.1 to OF5.1.8	
Pre-test conditions			
<ul style="list-style-type: none"> The IUT is in initial state as per sec 4.3.1 			
Test Sequence			
Step	Type	Description	Verdict
1	Configure	IUT to receive packets on <i>vChannel</i>	
2	Configure	Test Equipment to transmit <i>vNumberOfFrames</i> with a PSDU length of 1000 octets at a rate of one every 100msecs with <i>vChannel</i> , <i>vDataRate</i> and transmit power equal to minimum sensitivity as shown in table below. (Note: Receive Sensitivity exception for Channel 172; transmit messages with a PSDU length of 400 octets)	
3	Configure	The IUT to acknowledge all received packets to the test equipment.	
4	Stimulus	Test Equipment to transmit.	
5	Verify	The test equipment calculates the received PER and confirms it less than 10%.	PASS / FAIL
6	Procedure	Repeat steps 2-5 for each supported value of <i>vDataRate</i> in Table 4-2	
7	Procedure	Repeat steps 1-6 for each supported value of <i>vChannel</i> in Table 4-1	
8	Configure	The IUT to initial state	

Receive Sensitivity Table						
Data rate (Mb/s) (20 MHz channel spacing)	Data rate (Mb/s) (10 MHz channel spacing)	Minimum Sensitivity (dBm) (20 MHz Channel Spacing)	Minimum Sensitivity (dBm) (10 MHz Channel Spacing)	Modulation	Coding Rate (R)	This table is derived from 802.11 [2] to be tested with all channels except 172
6	3	-82	-85	BPSK	1/2	
9	4.5	-81	-84	BPSK	3/4	
12	6	-79	-82	QPSK	1/2	
18	9	-77	-80	QPSK	3/4	
24	12	-74	-77	16-QAM	1/2	

36	18	-70	-73	16-QAM	3/4	
48	24	-66	-69	64-QAM	2/3	
54	27	-65	-68	64-QAM	3/4	
12	6		-92	QPSK	1/2	As per J2945/1 [1] - Channel 172 only

6.2.4.2 TP-80211-RXT-PHY-BV-02

Test Purpose Id		TP-80211-RXT-PHY-BV-02	
Summary		To verify the OFDM adjacent channel rejection of the IUT is within conformance limits	
Test Configuration		TC3	
Reference:		[2] Clause 18, 18.3.10.3	
PICS Selection		OF5.7	
Pre-test conditions			
<ul style="list-style-type: none"> The IUT is in initial state as per sec 4.3.1 			
Test Sequence			
Step	Type	Description	Verdict
1	Configure	IUT to receive packets on <i>vChannel</i> .	
2	Configure	Test Equipment to continuously transmit interferer signal on a channel adjacent to <i>vChannel</i> with a power level equal to minimum receive sensitivity as shown in table below. The interfering signal in the adjacent channel shall be a conformant OFDM signal as specified in section 18.3.10.3 [2].	
3	Configure	Test Equipment to transmit <i>vNumberOfFrames</i> packets at a rate of one every 100msecs with a PSDU length of 1000 octets with <i>vChannel</i> , <i>vDataRate</i> and power 3dB above the rate dependent sensitivity as shown in table below. (Note: Exception for Channel 172; transmit messages with a PSDU length of 400 octets)	
4	Configure	The IUT to acknowledge all received packets to the test equipment.	
5	Stimulus	Test Equipment to transmit interferer signal and packets.	
6	Verify	Adjacent Channel Rejection greater than or equal to the value specified in table below when the PER is equal to or less than 10%	PASS/FAIL
7	Configure	Increase the interferer signal power level by 1 dB	
8	Procedure	Repeats steps 5-7 until interferer signal equals -53dBm	
9	Procedure	Repeat steps 2-8 for each supported value of <i>vDataRate</i> in Table 4-2	
10	Procedure	Repeat steps 1-9 for each supported value of <i>vChannel</i> in Table 4-1	
11	Configure	The IUT to initial state	

Receive Sensitivity Table							
Data rate (Mb/s) (20 MHz channel spacing)	Data rate (Mb/s) (10 MHz channel spacing)	Minimum Sensitivity (dBm) (20 MHz Channel Spacing)	Minimum Sensitivity (dBm) (10 MHz Channel Spacing)	Modulation	Coding Rate (R)	Adjacent Channel Rejection (dB)	This table is derived from 802.11 [2] to be tested
6	3	-82	-85	BPSK	1/2	16	

9	4.5	-81	-84	BPSK	3/4	15	with all channels except 172
12	6	-79	-82	QPSK	1/2	13	
18	9	-77	-80	QPSK	3/4	11	
24	12	-74	-77	16-QAM	1/2	8	
36	18	-70	-73	16-QAM	3/4	4	
48	24	-66	-69	64-QAM	2/3	0	
54	27	-65	-68	64-QAM	3/4	-1	
12	6		-92	QPSK	1/2		As per J2945/1 [1] - Channel 172 only

6.2.4.3 TP-80211-RXT-PHY-BV-03

Test Purpose Id		TP-80211-RXT-PHY-BV-03	
Summary		Verify the OFDM non adjacent channel rejection of IUT is within conformance limits	
Test Configuration		TC3	
Reference:		[2] Clause 18, 18.3.10.4	
PICS Selection		OF5.8	
Pre-test conditions			
<ul style="list-style-type: none"> The IUT is in initial state as per sec 4.3.1 			
Test Sequence			
Step	Type	Description	Verdict
1	Configure	IUT to receive packets on <i>vChannel</i>	
2	Configure	Test Equipment to continuously transmit interferer signal on a channel non-adjacent to <i>vChannel</i> with a power level equal to minimum receive sensitivity as shown in table below. The interfering signal in the non-adjacent channel shall be a conformant OFDM signal as specified in section 18.3.10.4 [2].	
3	Configure	Test Equipment to transmit <i>vNumberOfFrames</i> packets at a rate of one every 100msecs with a PSDU length of 1000 octets with <i>vChannel</i> , <i>vDataRate</i> and power 3db above the rate dependent sensitivity as shown in table below. (Note: Exception for Channel 172; transmit messages with a PSDU length of 400 octets)	
4	Configure	The IUT to acknowledge all received packets to the test equipment.	
5	Stimulus	Test Equipment to transmit interferer signal and packets.	
6	Verify	Non-Adjacent Channel Rejection greater than or equal to the value specified in table below when the PER is equal to or less than 10%	PASS/FAIL
7	Configure	Increase the interferer signal power level by 1 dBm	
8	Procedure	Repeats steps 5-7 until interferer signal equals -37dBm	
9	Procedure	Repeat steps 2-8 for each supported value of <i>vDataRate</i> in Table 4-2	
10	Procedure	Repeat steps 1-9 for each supported value of <i>vChannel</i> in Table 4-1	
11	Configure	The IUT to initial state	

Receive Sensitivity Table							
Data rate (Mb/s)	Data rate (Mb/s)	Minimum Sensitivity	Minimum Sensitivity	Modulation	Coding Rate	Non-Adjacent	This table is derived from

(20 MHz channel spacing)	(10 MHz channel spacing)	(dBm) (20 MHz Channel Spacing)	(dBm) (10 MHz Channel Spacing)		(R)	Channel Rejection (dB)	802.11 [2]
6	3	-82	-85	BPSK	1/2	32	to be tested with all channels except 172
9	4.5	-81	-84	BPSK	3/4	31	
12	6	-79	-82	QPSK	1/2	29	
18	9	-77	-80	QPSK	3/4	27	
24	12	-74	-77	16-QAM	1/2	24	
36	18	-70	-73	16-QAM	3/4	20	
48	24	-66	-69	64-QAM	2/3	16	
54	27	-65	-68	64-QAM	3/4	15	
12	6		-92	QPSK	1/2		As per J2945/1 [1] - Channel 172 only

6.2.4.4 TP-80211-RXT-PHY-BV-04

Test Purpose Id	TP-80211-RXT-PHY-BV-04		
Summary	To verify the receiver maximum input level of the IUT is within conformance limits		
Test Configuration	TC2		
Reference:	[2] Clause 18, 18.3.10.5		
PICS Selection	OF5.9		
Pre-test conditions			
<ul style="list-style-type: none"> The IUT is in initial state as per sec 4.3.1 			
Test Sequence			
Step	Type	Description	Verdict
1	Configure	IUT to receive packets on <i>vChannel</i>	
2	Configure	Test Equipment to transmit <i>vNumberOfFrames</i> with a PSDU length of 1000 octets at a rate of one every 100msecs with <i>vChannel</i> , <i>vDataRate</i> and power level of -30dBm. (Note: Exception for Channel 172; transmit messages with a PSDU length of 400 octets)	
3	Stimulus	Test Equipment to transmit.	
4	Verify	The test equipment calculates the received PER and confirms it is equal to or less than 10%.	PASS / FAIL
5	Procedure	Repeat steps 2-4 for each supported value of <i>vDataRate</i> in Table 4-2	
6	Procedure	Repeat steps 1-5 for each supported value of <i>vChannel</i> in Table 4-1	
7	Configure	The IUT to initial state	

6.2.4.5 TP-80211-RXT-PHY-BV-05

Test Purpose Id		TP-80211-RXT-PHY-BV-05	
Summary		To verify the received channel power indicator measurement of the IUT is within conformance limits and specified dynamic range of the receiver.	
Test Configuration		TC2	
Reference:		[2] Clause 18, 18.3.10.7	
PICS Selection		RM13.2	
Pre-test conditions			
<ul style="list-style-type: none"> The IUT is in initial state as per 4.3.1 			
Test Sequence			
Step	Type	Description	Verdict
1	Configure	IUT to receive packets on <i>vChannel</i>	
2	Configure	Test Equipment to transmit <i>vNumberOfFrames</i> frames at a rate of one every 100msecs with <i>vChannel</i> , <i>vDataRate</i> and power indicated by minimum sensitivity as in Receive Sensitivity table below.	
3	Stimulus	Test Equipment to transmit.	
4	Verify	RCPI shall be a monotonically increasing, logarithmic function of the received power level defined in dBm and shall be equal to the received RF power within an accuracy of ± 5 dB within the specified dynamic range of the receiver. The received RF power shall be determined assuming a receiver noise equivalent bandwidth equal to the channel bandwidth multiplied by 1.1	PASS / FAIL
5	Procedure	Repeat steps 2-4 with increasing power monotonically by 0.5dB until Test Equipment transmit power equals -30 dBm	
6	Procedure	Repeat steps 2-5 for each values of <i>vDataRate</i> in Table 4-2	
7	Procedure	Repeat steps 1-6 for each values of <i>vChannel</i> in Table 4-1	
8	Configure	The IUT to initial state	

Note: A 10% PER is acceptable.

RCPI Table		
Integer value	corresponding power value (dBm)	RCPI = Int{(Power in dBm +110) × 2} for 0 dBm > Power > - 110 dBm
0	Power ≤ - 110	
1	Power = - 109.5	
2	Power = - 109.0	
:	:	
:	:	
220	Power ≥ - 0	
221-254	Reserved	
255	Measurement not available	

Receive Sensitivity Table							
Data rate (Mb/s) (20 MHz channel spacing)	Data rate (Mb/s) (10 MHz channel spacing)	Minimum Sensitivity (dBm) (20 MHz Channel Spacing)	Minimum Sensitivity (dBm) (10 MHz Channel Spacing)	Modulation	Coding Rate (R)	Non-Adjacent Channel Rejection (dB)	
6	3	-82	-85	BPSK	1/2	32	This table is derived from 802.11 [2]
9	4.5	-81	-84	BPSK	3/4	31	
12	6	-79	-82	QPSK	1/2	29	
18	9	-77	-80	QPSK	3/4	27	
24	12	-74	-77	16-QAM	1/2	24	
36	18	-70	-73	16-QAM	3/4	20	
48	24	-66	-69	64-QAM	2/3	16	
54	27	-65	-68	64-QAM	3/4	15	
12	6		-92	QPSK	1/2		As per J2945/1 [1] - Channel 172 only

Appendix A: Traceability Matrix

802.11 PICS from [2]	Features in	Reference	Status	Support	Implemented? (True/False)	TP ID	TP Description
PC8, AD2, AD3, AD4, FR18	Data Frame Format	[1] Table 5, Clause: 8.3.2.1	M	V2V		TP-80211-RXT-MAC-BI-01	To Transmit WSMs with MAC field values other than those specified in J2945/1 V5, Table 5 (section 8.3.2.1) and verify that the IUT reject the frames.
		[1] Table 5, Clause: 8.3.2.1				TP-80211-RXT-MAC-BI-02	To Transmit WSMs with “Address1” and “Address3” fields in MAC frame other than specified in J2945/1 V5, Table 5 (section 8.3.2.1) and verify that the IUT reject the frames.
PC8, AD2, AD3, AD4, FR18	Data Frame Format	[1] Table 5, Clause: 8.3.2.1	M	V2V		TP-80211-RXT-MAC-BV-01	Transmit WSM to IUT(OBE) with MAC field values as per J2945/1 V5, Table 5 (section 8.3.2.1) and verify that IUT receives the frames
AD3, AD4	MAC Addressing	[2] Section 8.2.4.3.8	M	V2V		TP-80211-RXT-	Transmit WSM to IUT(OBE)

						MAC-BV-02	with static MAC address and verify all frames are received by IUT
PC8, AD2, AD3, AD4, FT18	Data Frame Format	[1] Table 5, Clause: 8.3.2.1	M	V2V		TP-80211-TXT-MAC-BV-01	Transmit WSM from IUT(RSE/OBE) and verify 802.11 Qos MAC formats and MAC field values
OF4.15, OF4.15.3, OF4.15.4	Transmit Spectral Mask	[2] Clause 18, 18.3.9.3, Annex D.2	M	V2V		TP-80211-TXT-PHY-BV-01	Verify Transmit spectral mask using spectral analyzer during IUT transmission
OF4.4	Center frequency tolerance	[2] Clause 18, 18.3.9.5	M	V2V		TP-80211-TXT-PHY-BV-02	Verify Center frequency tolerance of IUT are within conformance limit
OF4.5	Symbol clock frequency tolerance	[2] Clause 18, 18.3.9.6	M	V2V		TP-80211-TXT-PHY-BV-03	Verify symbol clock frequency tolerance of IUT are within conformance limit
OF4.6.3,OF4.6.4,OF4.6.5, OF4.6.6,OF4.6.7,OF4.6.8, OF4.6.9,OF4.6.10	Relative constellation RMS error and transmit modulation accuracy	[2] Clause 18, 18.3.9.7.4, 18.3.9.8	M	V2V		TP-80211-TXT-PHY-BV-04	Verify the relative constellation RMS error and transmit modulation accuracy of IUT is within conformance

							limit
OF4.6.2	Spectral Flatness	[2] Clause 18, 18.3.9.7.3	M	V2V		TP-80211-TXT-PHY-BV-05	Verify the observed power are within spectral flatness conformance limits.
OF4.6.1	Center frequency leakage	[2] Clause 18, 18.3.9.7.2	M	V2V		TP-80211-TXT-PHY-BV-06	Verify transmitter center frequency leakage is within conformance limits
-	Monotonically increasing transmit power	[1] 6.4.1.1				TP-80211-TXT-PHY-BV-07	Verify transmitter power is a monotonically increasing function of <i>vTxPwrCtrl Step</i> .
OF2.1, OF2.21, OF5.1, OF5.1.1 to OF5.1.8	Minimum input level	[2] Clause 18, 18.3.10.2	M	V2V		TP-80211-RXT-PHY-BV-01	Verify the receiver can operate at the specified minimum input level depending on the channel spacing.
OF5.7	Adjacent Channel Rejection	[2] Clause 18, 18.3.10.3	M	V2V		TP-80211-RXT-PHY-BV-02	Verify the OFDM adjacent channel rejection of the IUT is within conformance limits
OF5.8	Non-Adjacent Channel Rejection	[2] Clause 18, 18.3.10.4	M	V2V		TP-80211-RXT-PHY-BV-03	Verify the OFDM non adjacent channel rejection of IUT is within conformance

							limits
OF5.9	Receiver Maximum Input level	[2] Clause 18, 18.3.10.5	M	V2V		TP-80211-RXT-PHY-BV-04	Verify the receiver maximum input level of the device under test is within conformance limits
RM13.2	Received Channel Power Indicator	[2] Clause 18, 18.3.10.7	M	V2V		TP-80211-RXT-PHY-BV-05	Verify the received channel power indicator measurement of the IUT is within conformance limits

Appendix B: PIXIT proforma

B.1 System Specific Information

Identifier	Comment	Type	Default value	Test value(s)
PX_IP_address_IUT	IP address of IUT			
PX_IP_address_TS	IP address of Test System			
PX_TCP_port_IUT	TCP port used by Certification Interface to receive request from Test System.			
PX_TCP_port_TS	TCP port used by TS to listen for IUT indications and responses			

B.2 Test Purpose Parametric Information

Test Purpose	Identifier	Comment	Type	Default value	Test value(s)
T TP-80211-RXT-MAC-BI-01	<i>vNumberOfFrames</i>	Test system	Integer	100	100
	Tester Transmit Power	Test system; Power at IUT's connector	Integer	-30	
	WSM Payload	Test system	UChar[]		
	<i>vRadioNumber</i>	Supplier specific	Integer	0	0,1
	<i>vChannel</i>	Supplier specific	Integer	172	172, 178
	<i>vDataRate</i>	Supplier specific	Integer	6	6

Test Purpose	Identifier	Comment	Type	Default value	Test value(s)
TP-80211-RXT-MAC-BI-02	<i>vNumberOfFrames</i>	Test system	Integer	100	100
	Tester Transmit Power	Test system; Power at IUT's connector	Integer	-30	
	WSM Payload	Test system	UChar[]		
	<i>vRadioNumber</i>	Supplier specific	Integer	0	0,1
	<i>vChannel</i>	Supplier specific	Integer	172	172, 178
	<i>vDataRate</i>	Supplier specific	Integer	6	6

Test Purpose	Identifier	Comment	Type	Default value	Test value(s)
TP-80211-RXT-MAC-BV-01	<i>vNumberOfFrames</i>	Test system	Integer	100	100
	Tester Transmit Power	Test system; Power at IUT's connector	Integer	-30	
	WSM Payload	Test system	UChar[]		
	<i>vRadioNumber</i>	Supplier specific	Integer	0	0,1
	<i>vChannel</i>	Supplier specific	Integer	172	172, 178
	<i>vDataRate</i>	Supplier specific	Integer	6	6

Test Purpose	Identifier	Comment	Type	Default value	Test value(s)
TP-80211-RXT-MAC-BV-02	<i>vNumberOfFrames</i>	Test system	Integer	100	100
	Tester Transmit Power	Test system; Power at IUT's connector	Integer	-30	
	WSM Payload	Test system	UChar[]		
	<i>vRadioNumber</i>	Supplier specific	Integer	0	0,1
	<i>vChannel</i>	Supplier specific	Integer	172	172, 178
	<i>vDataRate</i>	Supplier specific	Integer	6	6

Test Purpose	Identifier	Comment	Type	Default value	Test value(s)
TP-80211-TXT-MAC-BV-01	<i>vNumberOfFrames</i>	Test system	Integer	100	100
	Tester Transmit Power	Test system; Power at IUT's connector	Integer	-30	
	WSM Payload	Test system	UChar[]		
	<i>vRadioNumber</i>	Supplier specific	Integer	0	0,1
	<i>vChannel</i>	Supplier specific	Integer	172	172, 178
	<i>vDataRate</i>	Supplier specific	Integer	6	6

Test Purpose	Identifier	Comment	Type	Default value	Test value(s)
TP-80211-TXT-PHY-BV-01	<i>vNumberOfFrames</i>	Test system	Integer	100	100
	<i>vTxPwrAcc</i>	Specified in 6.4.1.1, SAE J2945/1	dB	2	2
	<i>vTxPwrCtrlStep</i>	Specified in 6.4.1.1, SAE J2945/1	dB	1	1
	<i>vRadioNumber</i>	Supplier specific	Integer	0	0,1
	<i>MaxTxPowerCap</i>	Supplier specific	dBm	20	20
	<i>PwrRange</i>	Supplier specific	dBm	10	10
	<i>vChannel</i>	Supplier specific	Integer	172	172, 178
	<i>vDataRate</i>	Supplier specific	Integer	6	6
	<i>MaxTxPowerCap</i>	Supplier specific	dBm	20	20

Test Purpose	Identifier	Comment	Type	Default value	Test value(s)
TP-80211-TXT-PHY-BV-02	<i>vNumberOfFrames</i>	Test system	Integer	100	100
	<i>vTxPwrAcc</i>	Specified in 6.4.1.1, SAE J2945/1	dB	2	2
	<i>vTxPwrCtrlStep</i>	Specified in 6.4.1.1, SAE J2945/1	dB	1	1
	<i>vRadioNumber</i>	Supplier specific	Integer	0	0,1
	<i>MaxTxPowerCap</i>	Supplier specific	dBm	20	20
	<i>PwrRange</i>	Supplier specific	dBm	10	10
	<i>vChannel</i>	Supplier specific	Integer	172	172, 178
	<i>vDataRate</i>	Supplier specific	Integer	6	6

Test Purpose	Identifier	Comment	Type	Default value	Test value(s)
TP-80211-TXT-PHY-BV-03	<i>vNumberOfFrames</i>	Test system	Integer	100	100
	<i>vTxPwrAcc</i>	Specified in 6.4.1.1, SAE J2945/1	dB	2	2
	<i>vTxPwrCtrlStep</i>	Specified in 6.4.1.1, SAE J2945/1	dB	1	1
	<i>vRadioNumber</i>	Supplier specific	Integer	0	0,1
	<i>MaxTxPowerCap</i>	Supplier specific	dBm	20	20
	<i>PwrRange</i>	Supplier specific	dBm	10	10
	<i>vChannel</i>	Supplier specific	Integer	172	172, 178
<i>vDataRate</i>	Supplier specific	Integer	6	6	

Test Purpose	Identifier	Comment	Type	Default value	Test value(s)
TP-80211-TXT-PHY-BV-04	<i>vNumberOfFrames</i>	Test system	Integer	100	100
	<i>vTxPwrAcc</i>	Specified in 6.4.1.1, SAE J2945/1	dB	2	2
	<i>vTxPwrCtrlStep</i>	Specified in 6.4.1.1, SAE J2945/1	dB	1	1
	<i>vRadioNumber</i>	Supplier specific	Integer	0	0,1
	<i>MaxTxPowerCap</i>	Supplier specific	dBm	20	20
	<i>PwrRange</i>	Supplier specific	dBm	10	10
	<i>vChannel</i>	Supplier specific	Integer	172	172, 178
<i>vDataRate</i>	Supplier specific	Integer	6	6	

Test Purpose	Identifier	Comment	Type	Default value	Test value(s)
TP-80211-TXT-PHY-BV-05	<i>vNumberOfFrames</i>	Test system	Integer	100	100
	<i>vTxPwrAcc</i>	Specified in 6.4.1.1, SAE J2945/1	dB	2	2
	<i>vTxPwrCtrlStep</i>	Specified in 6.4.1.1, SAE J2945/1	dB	1	1
	<i>vRadioNumber</i>	Supplier specific	Integer	0	0,1
	<i>MaxTxPowerCap</i>	Supplier specific	dBm	20	20
	<i>PwrRange</i>	Supplier specific	dBm	10	10
	<i>vChannel</i>	Supplier specific	Integer	172	172, 178
<i>vDataRate</i>	Supplier specific	Integer	6	6	

Test Purpose	Identifier	Comment	Type	Default value	Test value(s)
TP-80211-TXT-PHY-BV-06	<i>vNumberOfFrames</i>	Test system	Integer	100	100
	<i>vTxPwrAcc</i>	Specified in 6.4.1.1, SAE J2945/1	dB	2	2
	<i>vTxPwrCtrlStep</i>	Specified in 6.4.1.1, SAE J2945/1	dB	1	1
	<i>vRadioNumber</i>	Supplier specific	Integer	0	0,1
	<i>MaxTxPowerCap</i>	Supplier specific	dBm	20	20
	<i>PwrRange</i>	Supplier specific	dBm	10	10
	<i>vChannel</i>	Supplier specific	Integer	172	172, 178
<i>vDataRate</i>	Supplier specific	Integer	6	6	

Test Purpose	Identifier	Comment	Type	Default value	Test value(s)
TP-80211-TXT-PHY-BV-07	<i>vNumberOfFrames</i>	Test system	Integer	100	100
	<i>vTxPwrAcc</i>	Specified in 6.4.1.1, SAE J2945/1	dB	2	2
	<i>vTxPwrCtrlStep</i>	Specified in 6.4.1.1, SAE J2945/1	dB	1	1
	<i>vRadioNumber</i>	Supplier specific	Integer	0	0,1
	<i>MaxTxPowerCap</i>	Supplier specific	dBm	20	20
	<i>PwrRange</i>	Supplier specific	dBm	10	10
	<i>vChannel</i>	Supplier specific	Integer	172	172, 178
<i>vDataRate</i>	Supplier specific	Integer	6	6	

Test Purpose	Identifier	Comment	Type	Default value	Test value(s)
TP-80211-RXT-PHY-BV-01	<i>vNumberOfFrames</i>	Test system	Integer	100	100
	Tester Transmit Power	Test system; Power at IUT's connector; dependent on vDataRate and Channel Spacing	Integer (dBm)	-92	
	<i>vRadioNumber</i>	Supplier specific	Integer	0	0,1
	<i>vChannel</i>	Supplier specific	Integer	172	172, 178
	<i>vDataRate</i>	Supplier specific	Integer	6	6

Test Purpose	Identifier	Comment	Type	Default value	Test value(s)
TP-80211-RXT-PHY-BV-02	<i>vNumberOfFrames</i>	Test system	Integer	100	100
			Integer		
	<i>vRadioNumber</i>	Supplier specific	Integer	0	0,1
	<i>vChannel</i>	Supplier specific	Integer	172	172, 178
	<i>vDataRate</i>	Supplier specific	Integer	6	6

Test Purpose	Identifier	Comment	Type	Default value	Test value(s)
TP-80211-RXT-PHY-BV-03	<i>vNumberOfFrames</i>	Test system	Integer	100	100
	Tester Transmit Power	Test system; Power at IUT's connector; dependent on <i>vDataRate</i> and Channel Spacing	Integer (dBm)	-92	
	<i>vRadioNumber</i>	Supplier specific	Integer	0	0,1
	<i>vChannel</i>	Supplier specific	Integer	172	172, 178
	<i>vDataRate</i>	Supplier specific	Integer	6	6

Test Purpose	Identifier	Comment	Type	Default value	Test value(s)
TP-80211-RXT-PHY-BV-04	<i>vNumberOfFrames</i>	Test system	Integer	100	100
	<i>vRadioNumber</i>	Supplier specific	Integer	0	0,1
	<i>vChannel</i>	Supplier specific	Integer	172	172, 178
	<i>vDataRate</i>	Supplier specific	Integer	6	6

Test Purpose	Identifier	Comment	Type	Default value	Test value(s)
TP-80211-RXT-PHY-BV-05	<i>vNumberOfFrames</i>	Test system	Integer	100	100
	<i>vTxPwrAcc</i>	Specified in 6.4.1.1, SAE J2945/1	dB	2	2
	<i>vTxPwrCtrlStep</i>	Specified in 6.4.1.1, SAE J2945/1	dB	1	1
	<i>vRadioNumber</i>	Supplier specific	Integer	0	0,1
	<i>MaxTxPowerCap</i>	Supplier specific	dBm	20	20
	<i>PwrRange</i>	Supplier specific	dBm	10	10
	<i>vChannel</i>	Supplier specific	Integer	172	172, 178
	<i>vDataRate</i>	Supplier specific	Integer	6	6

Revision History

V0.1.0	12/02/2015	Initial Draft
V0.2.0	12/03/2015	Updated Test Purpose ID's, Test Purposes, PICS and References.
V.0.3.0	12/28/2015	Updated PHY transmitter tests
V.0.4.0	2/4/2016	Major update following walkthrough with Noblis
V.0.5.0	2/23/2016	Format Updated
V.0.6.0	3/24/2016	Major update following walkthrough with industry experts

■ End of Document ■